

CATALOG

H&V Blower-Coil Units Horizontal and Vertical



TABLE OF CONTENTS

Features and Benefits2
 Features and Options.....3
 Construction Features4
 Applications5
 Coil and Filter Data6
 Coils and Static Pressure Data7
 Electric Heat8
 Fan Performance Data9
 Fan Performance Curves10
 Dimensional Data13
 H/V Blow-Thru Electric Heat13
 H, Discharge Arrangement 314
 V, Discharge Arrangement 2.....15
 H/V, Standard Mixing Box.....16
 H/V, Standard Flat Filter Rack17
 Unit Discharge Options17
 Electrical and Weight Data.....18
 Guide Specifications.....19

NOTES:

- ENVIRO-TEC offers Web-Select®, the industry’s first web-based rating and selection program for complete unit and coil selection.
- See your representative or visit our website at www.enviro-tec.com for more information.
- Some drawings are not shown in this catalog. Drawings are not for installation purposes.
- ETL Report Number 510580.
- MEA Number MEA 55-98-E applies to all units with any combination of chilled water or R-22 direct expansion coils and either hot water coils or electric heat.
- All data herein is subject to change without notice.



FEATURES AND BENEFITS

DESIGNED FOR MAXIMUM FLEXIBILITY

Both Horizontal and Vertical Belt Drive Blower Coils are designed to maximize flexibility of selection and installation.

The units will exceed the stringent quality standards of the institutional market, while remaining cost competitive in the light commercial segment of the market.

COMPONENT OPTIONS

The extensive variety of standard options available on the H & V units are where you find the versatility to fit any HVAC system designer’s needs.

Options include mixing boxes with standard low leak dampers, high efficiency filter sections for 2” prefilter and 4” final filter and blow thru electric heat with single point power connection. All Electric Heat units are listed with ETL as an assembly and carry the cETL label.

High Efficiency motors, starters, disconnects and fusing mean easier coordination between mechanical and electrical trades.

All H and V belt drive blower coils have the option of foil faced insulation.

COIL OPTIONS

Coil options allow for 4 or 6 row cooling coils. Water coils have optional circuiting that can be used to reduce

Water Pressure Drop, which may also allow for pipe size reductions and lower material cost. Hot Water or Standard Steam coils may be placed in the Preheat or Reheat position.

QUALITY PRODUCT

H and V belt drive blower coils are built from 18 gauge galvanized steel. This metal surpasses the ASTM 125 hour salt spray test for corrosion and rust. Standard insulation is 1 inch thick fiberglass, complying with UL 181 and NFPA 90A.

All units, with or without Electric Heat, are cETL listed and labeled. All wiring is in compliance with NEC, assuring safety and quality for the owner.

LOWER INSTALLED COST

All H or V belt drive blower coils are shipped completely assembled, reducing field installation time and labor. All units are thoroughly inspected and tested prior to shipment, eliminating potential problems at startup. Motor wiring is brought to a junction box on the outside of the unit casing, reducing electrical hook-up time.

A wide variety of fan discharge configurations allow for increased flexibility and easier installation on the jobsite, resulting in cost reductions by eliminating expensive elbows, etc.

FEATURES AND OPTIONS

STANDARD FEATURES

Construction

- Galvanized steel cabinet construction, minimum 18 gauge
- 1" thick fiberglass insulation
- 1" supply duct collars
- Gasketed, removable access panels sized for easy handling
- IAQ galvanized steel drain pan (not included with heating-only units)
- Left and right hand arrangement

Fan Assembly

- Forward curved (double width, double inlet) fans
- Statically and dynamically balanced
- Solid steel shafting
- Ball bearings with a minimum design average life (L50) of 100,000 hours

Fan Motor and Drive

- NEMA design ODP motors
- 1750 RPM single speed, 60 Hertz
- Single phase motors with inherent thermal protection
- Three phase motors
- Rigid mount adjustable motor base
- Standard cross section "V-belt" drive with 1.2 service factor
- Adjustable pitch motor pulley and fixed pitch blower pulley

Coils

- Coils are designed, manufactured and tested by ENVIRO-TEC
- AHRI 410 certified and labeled
- 1/2" O.D. seamless copper tubes
- High efficiency aluminum fin surface for optimizing heat transfer, pressure drop and carryover
- Mechanically expanded copper tubes leak tested to a minimum 450 PSIG air pressure under water
- Manual air vent plug on all water coils
- Copper ODM sweat connections
- 450 PSIG working pressure at 200°F
- Evaporator coils are factory sealed and charged with a minimum of 5 PSIG nitrogen or refrigerated dry air
- Steam coils rated at 15 PSIG maximum operating pressure at about 35°F
- 0.016" tube wall thickness (0.025" on steam)

Filters and Filter Rack

- Hinged side access flat filter rack
- Standard size 2" nominal throwaway filters
- Filter rack designed to accept 2" filters

Electrical

- Fan motor wired and terminated to J-Box
- All units cETL listed in compliance with UL/ANSI Standard 1995

OPTIONAL FEATURES

Construction

- IAQ stainless steel drain pan with 1" MPT galvanized pipe outlet
- External rubber-in-shear or spring type vibration isolators, hangers or floor mount
- Fan discharge arrangements
- Scrim reinforced foil faced insulation
- Hinged access panels with lift and turn fasteners
- Base rails with rigging slots factory assembled and installed
- Auxiliary (secondary) drain connections

Fan Motor and Drive

- High efficiency motors
- TEFC motors

Coils

- 3, 4 and 6 row chilled water or DX coils
- 1 and 2 row hot water or standard steam coils
- Heating coil in preheat or reheat position
- Coil connections opposite handing
- Stainless steel coil casings
- Automatic air vents on water coils
- Heat pump compatible cooling coils
- 0.025" tube wall thickness

Filters

- 2" pleated filter
- Spare throwaway or pleated filters
- High efficiency filter rack with 2" and 4" filters

Inlet Damper Section

- Factory assembled and installed
- Heavy gauge galvanized steel formed blade dampers
- Low leak dampers with extruded vinyl blade seals and flexible metal jamb seals
- Parallel blade operation
- Interconnecting damper linkage

Electrical

- Motor wiring on conduit
- Motor starter (contactor with overload for three phase; contactor for single phase), factory installed (mounted and wired)
- Door interlocking disconnect switch (non-fused)
- Hand off auto switch (HOA)
- Main fusing

Electric Heat Section

- Factory mounted electric heater with single point power connection, cETL listed as an assembly (see page 8)

CONSTRUCTION FEATURES

MODEL H

Hanger holes in top and bottom panels for thru rod installation

18 gauge galvanized steel casing withstanding 125 hour salt spray test per ASTM B-117

Product label including tagging, airflow and electrical information

Pipe stubouts extend through unit casing

ETL label

Forward curved fan

Access panels on both sides for easy access to blower and motor. Optional hinged panels with lift and turn fasteners

NEMA 1 control enclosure



MODEL V

Multi-bend construction for optimum strength and rigidity

1" duct collar allows for quick field connection of duct work

Control enclosure houses optional starter, disconnect, fusing and more

Full size access panels

Filter rack design allows for 2" filter

Cooling coil panels have oversized holes with pipe insulation extended to coil header

3, 4 or 6 row cooling coil with 1 or 2 row heating coil in preheat or reheat

Hinged filter access on both sides



APPLICATIONS

APPLICATION CONSIDERATIONS

Model H & V Belt Drive Blower Coils offer a wide range of application flexibility, while maintaining a simple, easy to install unit design. These units are intended to provide comfort cooling and heating within a small footprint. They may be applied in many types of building structures including schools, office buildings, hospitals, condominiums, assisted living facilities, apartments or stores. Applications can be constant or variable volume.

There are many applications the H & V product can be utilized. Some examples are listed below.

Constant volume applications:

- Two-pipe hydronic system for cooling and/or heating.
- Two-pipe hydronic cooling system with electric heat.
- Four-pipe system with dedicated heating and cooling coils.
- Direct Expansion (DX) split systems with hydronic heat.
- Direct Expansion (DX) split systems with electric heat.

Variable volume applications:

- Two-pipe hydronic system for cooling and/or heating.
- Two-pipe hydronic cooling system with electric heat.
- Four-pipe system with dedicated heating and cooling coils.

ACOUSTICS

Control of noise within both occupied and unoccupied spaces has become increasingly important to designers and building owners/occupants. Proper consideration must be given to placement of indoor air conditioning units, particularly in the occupied space. Inherent flexibility of the fan and coil combination in the vertical configuration allows application in sound-sensitive areas. In such instances, a fan running at a low speed with a high capacity coil normally yields satisfactory results. It also may be desirable to select a larger nominal capacity unit and operate it at a less than nominal airflow for further acoustic benefit.

Three phase motors are recommended for sound-sensitive applications to avoid potential single phase motor hum. Unit operation in the stall region of the fan curve is not recommended since it may cause unsatisfactory noise levels and excessive unit vibration.

INSTALLATION

These floor mounted or ceiling hung units can be installed with external vibration isolation on a base rail (H or V) or hanger rods (H only) at the corner points. This requires flex connections at the corner brackets, ductwork, electrical connections and piping connections. One of the most important and basic IAQ issues is condensate management. The first step to trouble-free operation is proper installation. It is very important that the unit be mounted high enough so that the condensate drain from the unit may be properly trapped. Please refer to the H & V IOM Manual at www.enviro-tec.com for specifics on this issue. As with all HVAC systems, these units should be installed according to all applicable ASHRAE standards, SMACNA and local code requirements.

OPERATING LIMITATIONS

Units must not be operated above maximum fan speed or unit airflow as listed in the Fan Performance section of this catalog. Unit operation at greater than maximum fan speed could drastically reduce bearing life and may result in a catastrophic wheel failure. Operating at greater than the maximum allowable airflow in the cooling mode may result in unsatisfactory operation due to moisture carry over from the coil. In addition, it is often not economical to operate a unit at its maximum fan speed due to the greater motor power requirements.

Units with electric heat should not be operated with leaving air temperature greater than 104°F (40°C), to prevent excessive leaving air temperatures and electric heat limit trips. A hydronic (or steam) coil and electric heat should not be operated simultaneously to prevent excessive leaving air temperatures and limit trips. Electric heat units are equipped with a high limit lockout switch that disables the electric heater if the temperature of the hydronic coil is greater than 104°F (40°C).

Water coils must not be operated above a fluid velocity of 8 ft./sec. to reduce the possibility of velocity induced erosion and flow noise. Water coils must not be operated below a fluid velocity of 1 ft./sec. to prevent degraded coil performance caused by laminar flow. These high or low fluid flow rates may not be included in the AHRI coil certification.

COIL AND FILTER DATA

COIL AND FILTER DATA

UNIT SIZE	COIL FACE AREA	2" FLAT FILTERS (QUANTITY) and SIZE	FILTER FACE AREA
08	2.1 [0.20]	(1) 16 x 20 x 2 [406 x 508 x 51]	2.2 [0.20]
12	2.7 [0.25]	(1) 16 x 25 x 2 [406 x 635 x 51]	2.8 [0.26]
16	3.5 [0.33]	(2) 16 x 20 x 2 [406 x 508 x 51]	4.4 [0.41]
20	4.9 [0.46]	(1) 16 x 20 x 2 [406 x 508 x 51] (1) 16 x 25 x 2 [406 x 635 x 51]	5.0 [0.46]
30	6.5 [0.60]	(2) 16 x 25 x 2 [406 x 635 x 51] (1) 20 x 25 x 2 [508 x 635 x 51]	9.0 [0.84]
40	8.4 [0.78]	(3) 20 x 25 x 2 [508 x 635 x 51]	10.4 [0.97]

NOTES:

- Standard filters are 2" throwaway.
- Filter sizes are nominal and standard size, measured in inches [millimeters].
- Coil and filter face areas are measured in square feet [square meters].
- Cooling and heating coils have same face area.

NOMINAL COIL CONNECTION SIZES

UNIT SIZE	COIL TYPE														
	WATER					STEAM				REFRIGERANT					
	1 ROW	2 ROW	3 ROW	4 ROW	6 ROW	1 ROW		2 ROW		3 ROW		4 ROW		6 ROW	
						STM.	COND.	STM.	COND.	LIQUID	SUCT.	LIQUID	SUCT.	LIQUID	SUCT.
08	5/8" [16]	5/8" [16]	7/8" [22]	7/8" [22]	7/8" [22]	1 1/8" [29]	7/8" [22]	1 1/8" [29]	7/8" [22]	5/8" [16]	5/8" [16]	5/8" [16]	5/8" [16]	5/8" [16]	5/8" [16]
12	5/8" [16]	5/8" [16]	7/8" [22]	7/8" [22]	7/8" [22]	1 1/8" [29]	7/8" [22]	1 1/8" [29]	7/8" [22]	5/8" [16]	7/8" [22]	5/8" [16]	7/8" [22]	5/8" [16]	7/8" [22]
16	5/8" [16]	7/8" [22]	7/8" [22]	7/8" [22]	1 1/8" [29]	1 1/8" [29]	7/8" [22]	1 3/8" [35]	1 1/8" [29]	5/8" [16]	7/8" [22]	5/8" [16]	7/8" [22]	5/8" [16]	7/8" [22]
20	5/8" [16]	7/8" [22]	1 1/8" [29]	1 1/8" [29]	1 1/8" [29]	1 3/8" [35]	1 1/8" [29]	1 3/8" [35]	1 1/8" [29]	5/8" [16]	7/8" [22]	5/8" [16]	7/8" [22]	5/8" [16]	7/8" [22]
30	7/8" [22]	1 1/8" [29]	1 1/8" [29]	1 1/8" [29]	1 3/8" [35]	1 5/8" [41]	1 1/8" [29]	1 5/8" [41]	1 1/8" [29]	5/8" [16]	1 1/8" [29]	5/8" [16]	1 1/8" [29]	5/8" [16]	1 1/8" [29]
40	1 1/8" [29]	1 3/8" [35]	1 3/8" [35]	1 3/8" [35]	1 5/8" [41]	2 1/8" [54]	1 3/8" [35]	2 1/8" [54]	1 3/8" [35]	5/8" [16]	1 1/8" [29]	5/8" [16]	1 1/8" [29]	7/8" [22]	1 3/8" [35]

NOTES:

- Water coils are based on Standard GPM Circuiting. Consult factory for applications requiring special circuiting.
- For other selections, refer to Web-Select®.
- Refrigerant coil connection sizes for single circuit coils and may vary with application. Contact factory for double circuit coils.
- All dimensional data is outside diameter (O.D.), measured in inches [millimeters].
- See page 3 for a list of standard and optional features of coils.

COILS AND STATIC PRESSURE DATA

COILS

ENVIRO-TEC offers hot water, chilled water and direct expansion (DX) coils for specific application with all Model H and V blower coils. AHRI 410 certified and labeled, and strict on-site inspection before, during, and after installation guarantees the highest quality and performance available.

STANDARD FEATURES

- Coils are designed, manufactured and tested by ENVIRO-TEC
- AHRI 410 certified and labeled
- 1/2" O.D. seamless copper tubes
- High efficiency aluminum fin surface for optimizing heat transfer, pressure drop and carryover
- Mechanically expanded copper tubes leak tested to a minimum 450 PSIG air pressure under water
- Manual air vent plug on all water coils
- Copper ODM sweat connections
- 450 PSIG working pressure at 200°F
- Evaporator coils are factory sealed and charged with a minimum of 5 PSIG nitrogen or refrigerated dry air
- Refrigerant coils are provided with distributor (metering device field-provided)
- Steam coils rated at 15 PSIG maximum operating pressure at about 35°F
- 0.016" tube wall thickness (0.025" on steam)

OPTIONAL FEATURES

- Stainless steel coil casings
- Automatic air vents on water coils
- Heat pump compatible cooling coils
- 0.025" tube wall thickness



COMPONENT STATIC PRESSURE LOSS – INCHES W.G.

UNIT SIZE	NOMINAL CFM	CABINET	FILTER (2" T/A)	COIL					INLET DAMPER SECTION	ELECTRIC HEAT SECTION
				1 ROW	2 ROW	3 ROW	4 ROW	6 ROW		
08	800	0.09	0.25	0.05	0.10	0.23	0.31	0.47	0.04	0.05
12	1200	0.09	0.25	0.06	0.12	0.29	0.39	0.58	0.06	0.05
16	1600	0.10	0.25	0.06	0.13	0.30	0.40	0.60	0.09	0.05
20	2000	0.11	0.25	0.06	0.11	0.26	0.35	0.52	0.05	0.05
30	3000	0.14	0.25	0.07	0.13	0.31	0.41	0.61	0.08	0.05
40	4000	0.16	0.25	0.07	0.14	0.32	0.43	0.64	0.07	0.05

NOTES:

1. All static pressures are at nominal CFM.
2. Coil static pressure for standard coil, 10FPI at 80/67 EAT and 45° EWT with 10° rise.
3. For 8, 12 or 14 FPI, refer to Web-Select®, available at www.enviro-tec.com.
4. Filter static pressure based on 50% loaded filter.
5. If pleated filters are used in lieu of throwaway, the filter static pressure loss is 0.35.

FAN PERFORMANCE DATA

FORWARD CURVED FAN PERFORMANCE DATA

TSP	Unit Size	08					12					16				
[In-wg]	Actual CFM	600	700	800	900	1000	1000	1100	1200	1300	1400	1400	1500	1600	1700	1800
2.4	RPM					1714					1674					
	BHP					0.72					1.08					
2.2	RPM				1637	1649				1594	1614					1407
	BHP				0.58	0.68				0.9	1.01					1.08
2	RPM				1563	1586				1533	1551					1341 1346
	BHP				0.54	0.62				0.84	0.93					0.93 0.99
1.8	RPM			1480	1491	1526			1447	1466	1483			1272	1276	1281
	BHP			0.43	0.5	0.58			0.69	0.77	0.84			0.79	0.84	0.9
1.6	RPM			1398	1421	1468		1358	1378	1395	1415		1199	1203	1208	1214
	BHP			0.38	0.45	0.55		0.55	0.63	0.69	0.76		0.65	0.7	0.76	0.82
1.4	RPM		1305	1316	1354	1414		1285	1302	1321	1348	1121	1125	1131	1137	1144
	BHP		0.29	0.34	0.41	0.52		0.5	0.56	0.62	0.71	0.53	0.58	0.62	0.68	0.73
1.2	RPM		1211	1238	1292	1367	1186	1204	1222	1249	1276	1042	1048	1055	1062	1071
	BHP		0.25	0.31	0.39	0.48	0.39	0.44	0.49	0.56	0.65	0.46	0.5	0.55	0.6	0.65
1	RPM	1104	1119	1166	1238	1322	1098	1117	1144	1170	1193	958	966	974	982	991
	BHP	0.18	0.22	0.28	0.36	0.45	0.33	0.37	0.44	0.5	0.56	0.39	0.43	0.48	0.52	0.57
0.8	RPM	994	1034	1103	1188	1276	1003	1030	1055	1081	1116	868	877	886	896	908
	BHP	0.15	0.19	0.25	0.32	0.42	0.28	0.33	0.38	0.43	0.51	0.33	0.37	0.4	0.44	0.49
0.6	RPM	892	961	1047	1134	1220	905	929	962	999	1038	768	779	792	807	824
	BHP	0.12	0.17	0.22	0.3	0.41	0.23	0.27	0.33	0.39	0.46	0.27	0.3	0.33	0.37	0.42
Fan Size		0904R					0906R					1008R				
Coil Face Area		2.1					2.7					3.5				
FPM @ CFM		286	333	381	429	476	370	407	444	481	519	400	429	457	486	514

TSP	Unit Size	20					30					40				
[In-wg]	Actual CFM	1800	1950	2100	2250	2400	2600	2800	3000	3200	3400	3600	3800	4000	4200	4400
2.4	RPM					1597				1028	1028				1058	1062
	BHP					1.3				2.37	2.55				2.84	3.06
2.2	RPM				1532	1523				984	987			1013	1017	1022
	BHP				1.11	1.21				2.19	2.36			2.48	2.67	2.86
2	RPM			1463	1454	1449			938	940	945	965	969	975	981	
	BHP			0.94	1.02	1.12			1.86	2.01	2.16	2.13	2.31	2.48	2.66	
1.8	RPM			1382	1375	1367		890	891	896	903	920	925	932	940	
	BHP			0.86	0.94	1.02		1.56	1.69	1.83	1.96	1.98	2.13	2.29	2.47	
1.6	RPM		1304	1297	1290	1273	839	840	844	851	858	867	873	880	888	897
	BHP		0.7	0.78	0.85	0.89	1.28	1.4	1.52	1.64	1.76	1.67	1.81	1.95	2.12	2.3
1.4	RPM	1222	1214	1207	1190	1182	785	790	796	803	808	818	825	834	844	855
	BHP	0.57	0.63	0.69	0.73	0.77	1.14	1.24	1.34	1.46	1.6	1.51	1.64	1.79	1.96	2.17
1.2	RPM	1124	1117	1100	1094	1096	731	738	744	750	761	767	777	787	799	811
	BHP	0.5	0.55	0.58	0.62	0.67	0.99	1.08	1.18	1.3	1.45	1.35	1.49	1.66	1.84	2.03
1	RPM	1017	1002	998	1003	1015	675	681	689	701	715	716	727	739	751	762
	BHP	0.42	0.45	0.49	0.53	0.59	0.83	0.93	1.04	1.17	1.32	1.22	1.37	1.53	1.68	1.84
0.8	RPM	894	894	904	916	929	612	623	637	652	666	662	674	686	698	712
	BHP	0.33	0.36	0.41	0.46	0.51	0.7	0.8	0.92	1.05	1.19	1.11	1.23	1.36	1.49	1.63
0.6	RPM	781	793	806	820	836	552	567	581	597	614	603	616	630	646	661
	BHP	0.26	0.3	0.33	0.38	0.42	0.6	0.7	0.8	0.93	1.06	0.95	1.05	1.17	1.3	1.44
Fan Size		1010R					1509R					1511R				
Coil Face Area		4.9					6.5					8.4				
FPM @ CFM		367	398	429	459	490	400	431	462	492	523	429	452	476	500	524

NOTES:

1. Consult factory for applications at operating conditions not shown above.
2. Fan motor voltage, fan rotation, and fan RPM may require field setting/adjustment.
3. Drive losses not included in fan performance.

FAN PERFORMANCE CURVES

UNIT SIZE 08 (FAN 0904R)

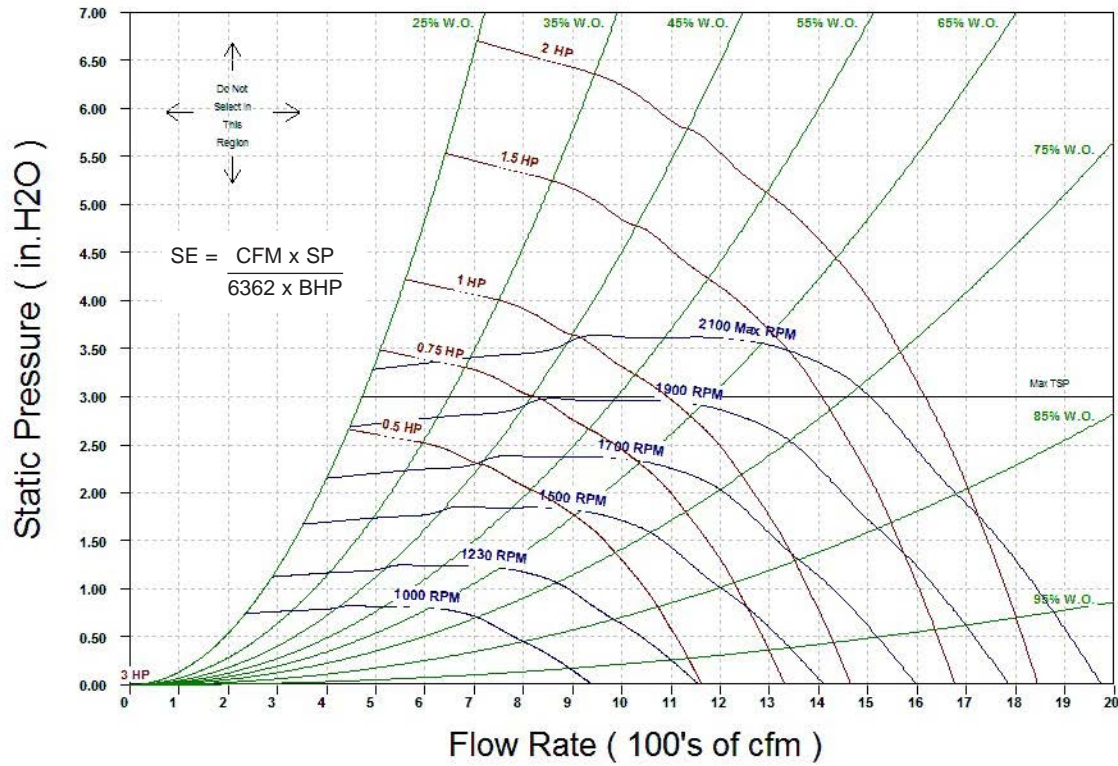

UNIT SIZE 12 (FAN 0906R)

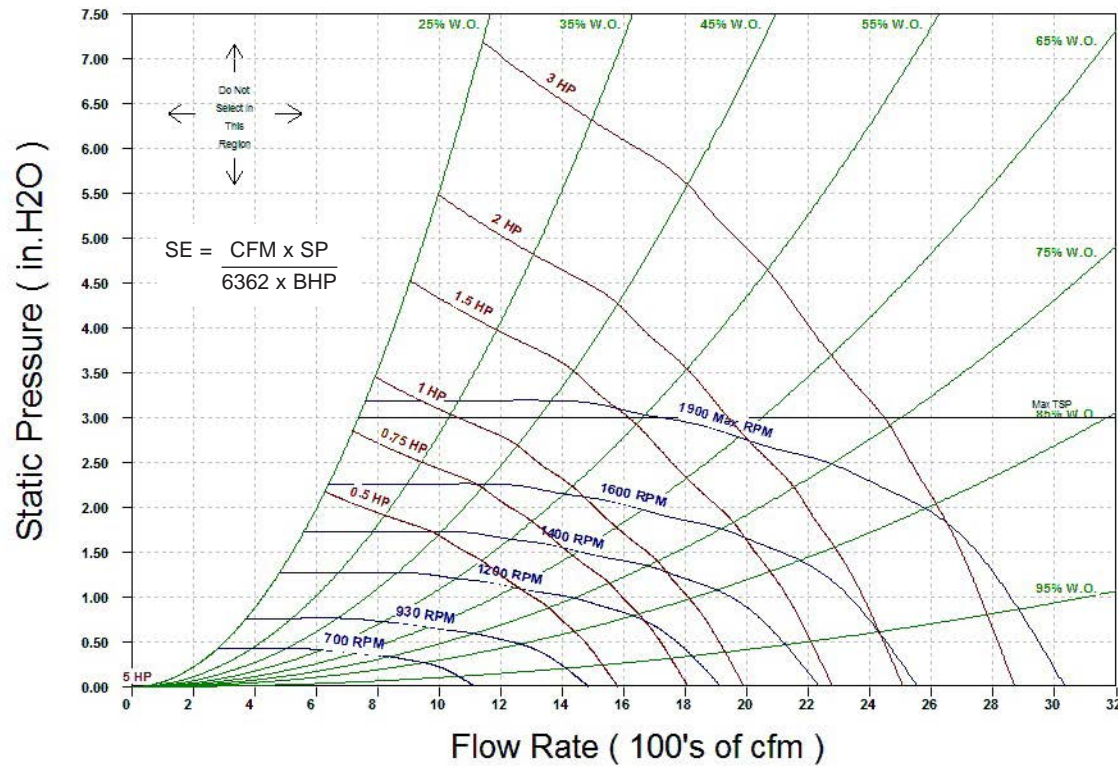

FAN PERFORMANCE CURVES

UNIT SIZE 16 (FAN 1008R)

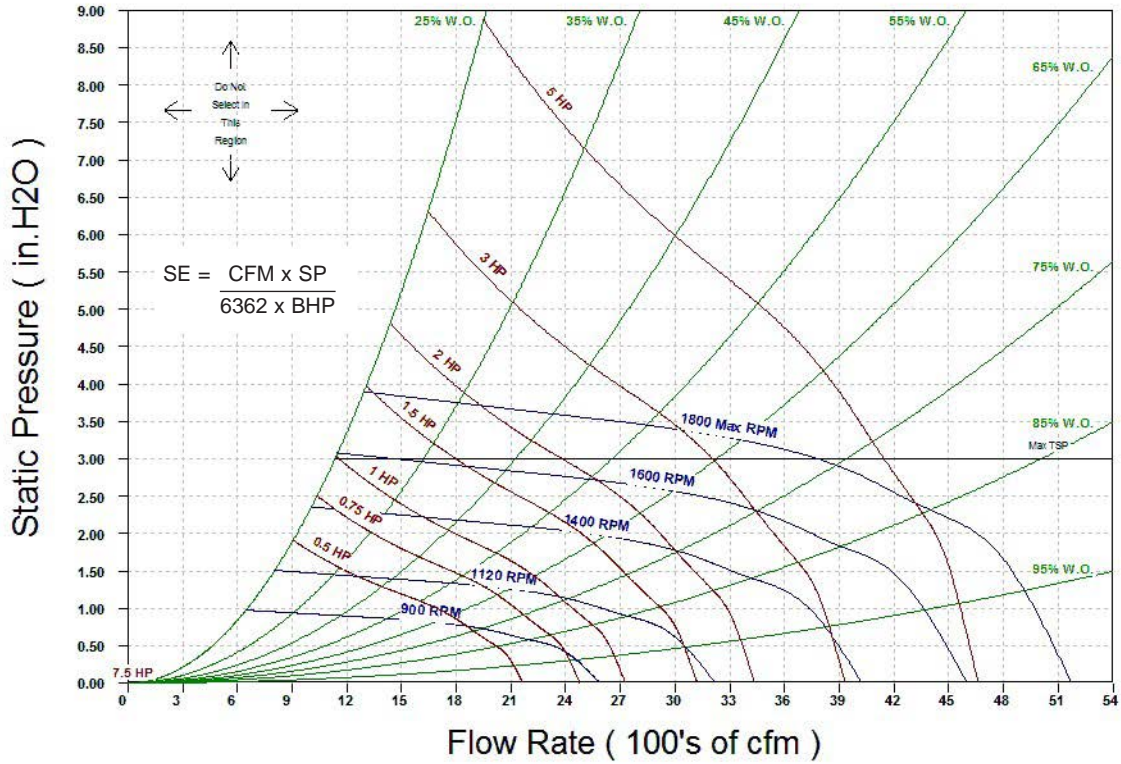

UNIT SIZE 20 (FAN 1010R)

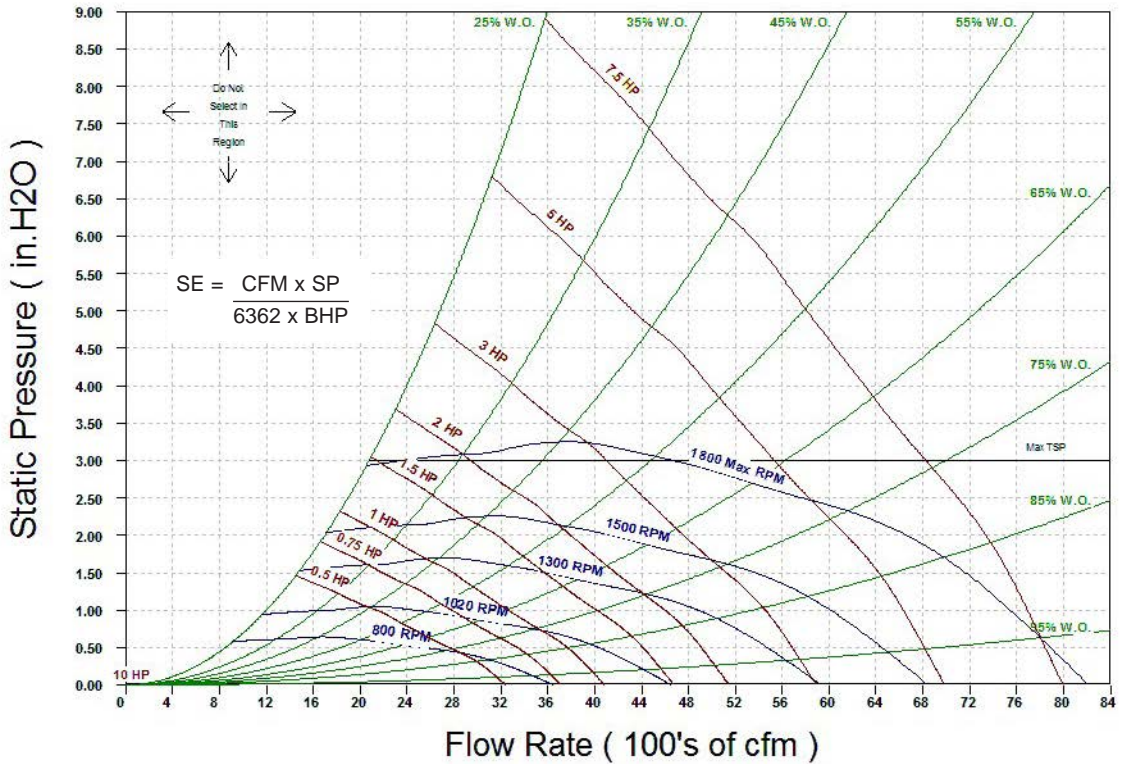

FAN PERFORMANCE CURVES

UNIT SIZE 30 (FAN 1509R)

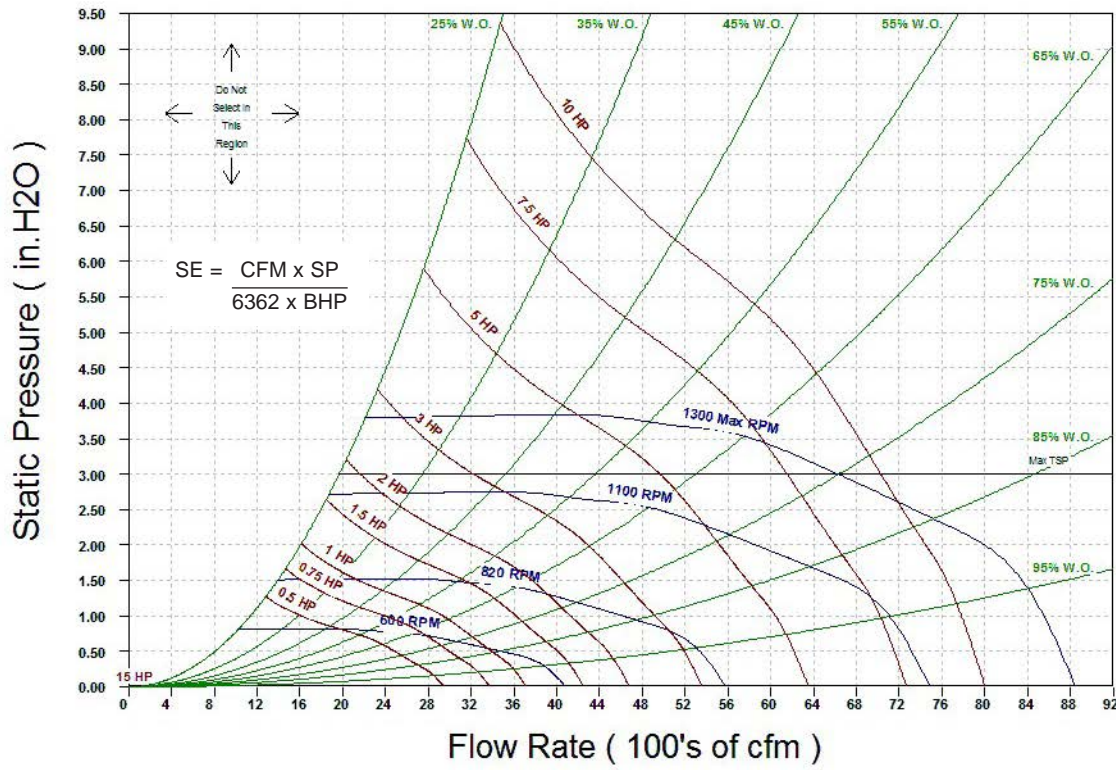

UNIT SIZE 40 (FAN 1511R)

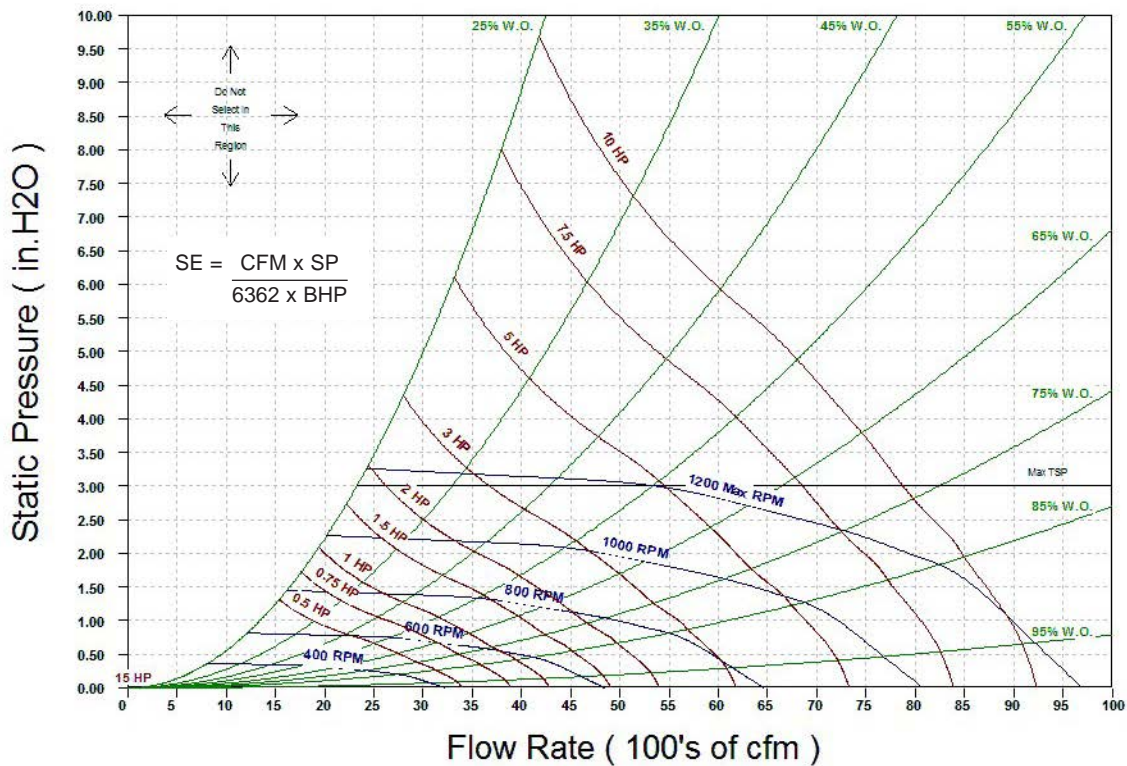

DIMENSIONAL DATA

MODEL H/V, BLOW THRU ELECTRIC HEAT

Drawings are not to scale and are not for installation purposes.

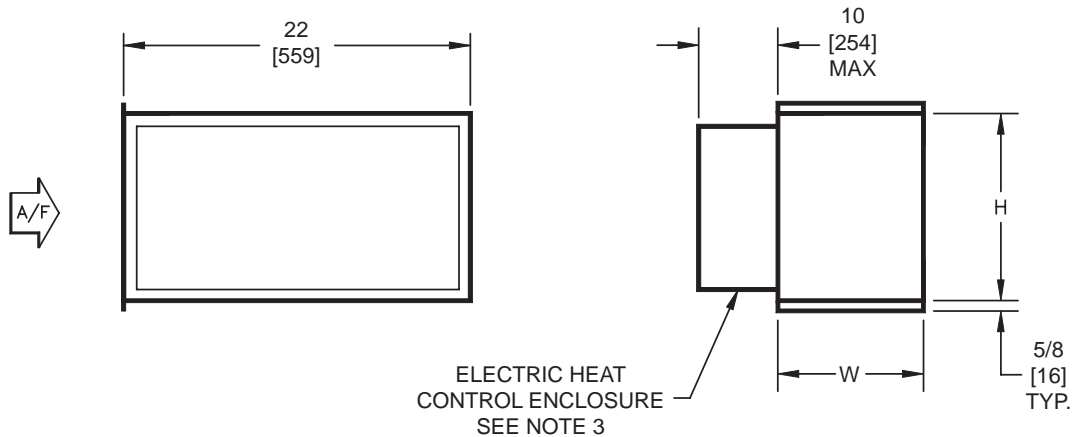

NOTES:

1. All dimensions are inches [millimeters]. All dimensions are $\pm 1/4"$ [6mm]. Metric values are soft conversion.
2. Motor/drive location may be specified Left or Right Hand. Standard control enclosure location matches motor/drive position.
3. Provide sufficient clearance to permit access to controls and comply with applicable codes and ordinances.
4. Available for horizontal discharge only.

BT BLOW THRU ELECTRIC HEAT SECTION

DIMENSIONS - in [mm]

UNIT SIZE	H	W	Weight lbs [kg]
08	11-7/8 [302]	8-7/8 [225]	42 [19]
12	11-7/8 [302]	8-7/8 [225]	42 [19]
16	12 [305]	10-7/8 [278]	42 [19]
20	12 [305]	13-7/8 [352]	50 [23]
30	16-5/8 [422]	13-7/8 [352]	55 [25]
40	16-5/8 [422]	15-5/8 [397]	55 [25]

DIMENSIONAL DATA

MODEL H, DISCHARGE ARRANGEMENT 3

Drawings are not to scale and are not for installation purposes.

NOTES:

1. All dimensions are Inches [millimeters].
All dimensions are $\pm 1/4"$ [6mm]. Metric values are soft conversion.
2. Right hand unit shown, left hand unit opposite. Motor/drive location may be specified Left or Right Hand. Standard control enclosure location matches motor/drive position.
3. Provide sufficient clearance to permit access to controls and comply with applicable codes and ordinances.
4. See drawing FR-001 for filter rack details.
5. Base rail is optional on the base unit. See drawing BR-001. Base rails must be used with mixing box.
6. See coil connection detail drawings for coil connection sizes and locations.

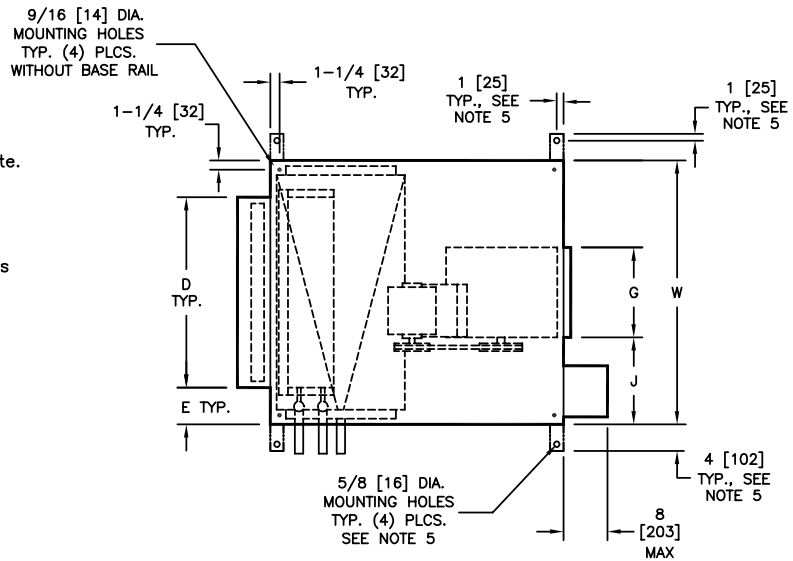

TOP VIEW

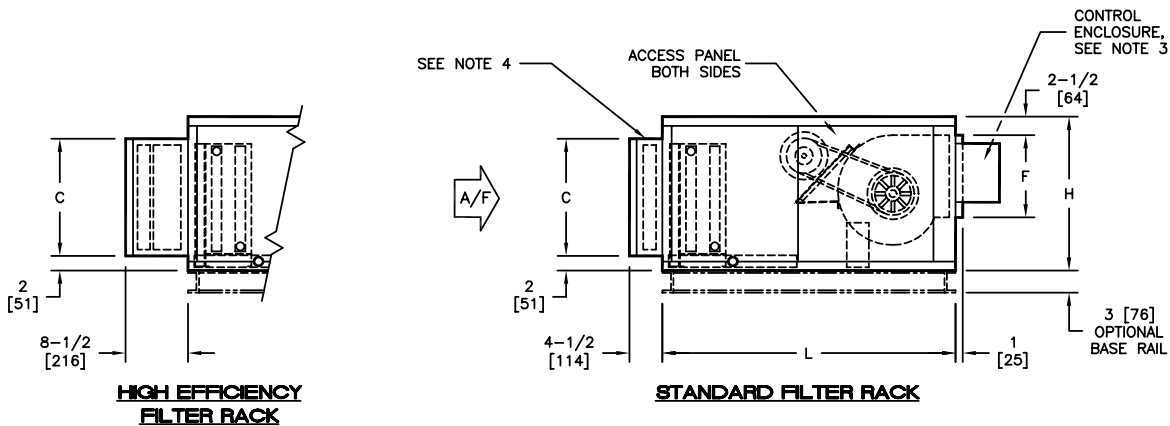

SIDE VIEWS

DIMENSIONS

SIZE	FAN SIZE	L	W	H	C	D	E	F	G	J
08	9 X 4 [229 X 102]	40 [1016]	30 [762]	21 [533]	16 [406]	20 [508]	5 [127]	10-1/4 [260]	6-7/8 [175]	11-9/16 [294]
12	9 X 6 [229 X 152]	40 [1016]	36 [914]	21 [533]	16 [406]	25 [635]	5-1/2 [140]	11-1/4 [286]	8-1/4 [210]	13-7/8 [352]
16	10 X 8 [254 X 203]	40 [1016]	44 [1118]	21 [533]	16 [406]	39-1/2 [1003]	2-1/4 [57]	11-3/8 [289]	10-1/4 [260]	16-7/8 [429]
20	10 X 10 [254 X 254]	40 [1016]	50 [1270]	21 [533]	16 [406]	44-1/2 [1130]	2-3/4 [70]	11-3/8 [289]	13-1/4 [337]	18-3/8 [467]
30	15 X 9 [381 X 229]	46 [1168]	59 [1499]	30 [762]	25 [635]	51 [1295]	4 [102]	16 [406]	13-1/4 [337]	22-7/8 [581]
40	15 X 11 [381 X 279]	46 [1168]	68 [1727]	30 [762]	25 [635]	59 [1499]	4-1/2 [114]	16 [406]	15 [381]	26-1/2 [673]

DIMENSIONAL DATA

MODEL V, DISCHARGE ARRANGEMENT 2

Drawings are not to scale and are not for installation purposes.

NOTES:

1. All dimensions are Inches [millimeters]. All dimensions are $\pm 1/4"$ [6mm]. Metric values are soft conversion.
2. Right hand unit shown, left hand unit opposite. Motor/drive location may be specified Left or Right Hand. Standard control enclosure location matches motor/drive position.
3. Provide sufficient clearance to permit access to controls and comply with applicable codes and ordinances.
4. Flat filter rack may be located at unit inlet as required. See drawing FR-001 for filter rack details.
5. Base rail is optional on the base unit. See drawing BR-001. Base rails must be used with mixing box.
6. See coil connection detail drawings for coil connection sizes and locations.

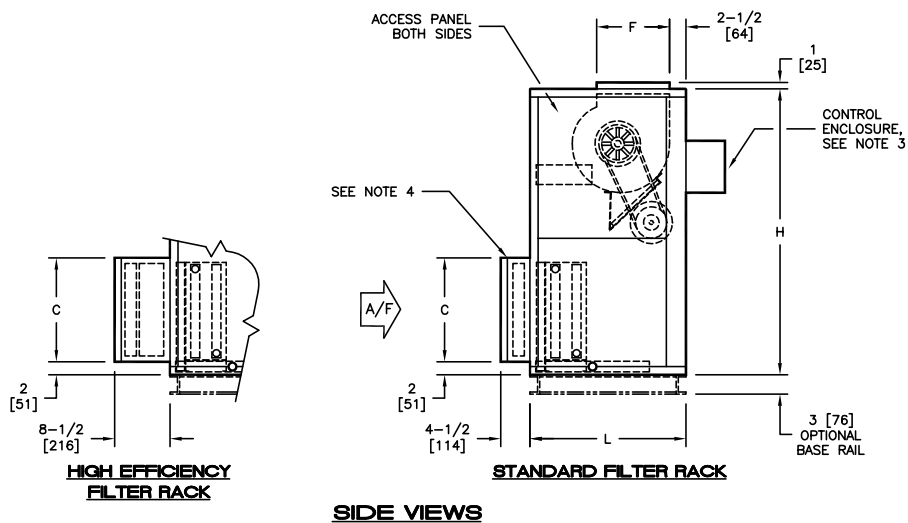
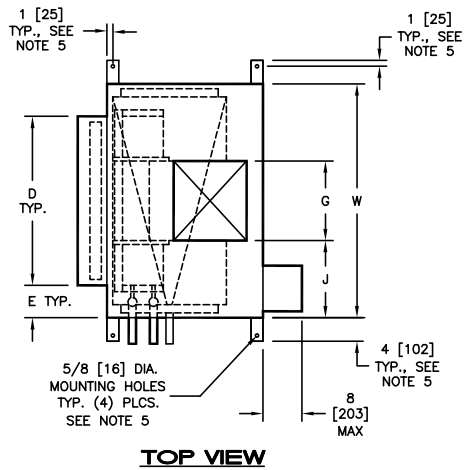

DIMENSIONS

SIZE	FAN SIZE	L	W	H	C	D	E	F	G	J
08	9 X 4 [229 X 102]	24 [610]	30 [762]	44 [1118]	16 [406]	20 [508]	5 [127]	10-1/4 [260]	6-7/8 [175]	11-9/16 [294]
12	9 X 6 [229 X 152]	24 [610]	36 [914]	44 [1118]	16 [406]	25 [635]	5-1/2 [140]	10-1/4 [260]	8-1/4 [210]	13-7/8 [352]
16	10 X 8 [254 X 203]	24 [610]	44 [1118]	44 [1118]	16 [406]	39-1/2 [1003]	2-1/4 [57]	11-3/8 [289]	10-1/4 [260]	16-7/8 [429]
20	10 X 10 [254 X 254]	30 [762]	50 [1270]	50 [1270]	16 [406]	44-1/2 [1130]	2-3/4 [70]	11-3/8 [289]	13-1/4 [337]	18-3/8 [467]
30	15 X 9 [381 X 229]	30 [762]	59 [1499]	56 [1422]	25 [635]	51 [1295]	4 [102]	16 [406]	13-1/4 [337]	22-7/8 [581]
40	15 X 11 [381 X 279]	30 [762]	68 [1727]	59 [1499]	25 [635]	59 [1499]	4-1/2 [114]	16 [406]	15 [381]	26-1/2 [673]

DIMENSIONAL DATA

MODEL H/V, STANDARD MIXING BOX

Drawings are not to scale and are not for installation purposes.

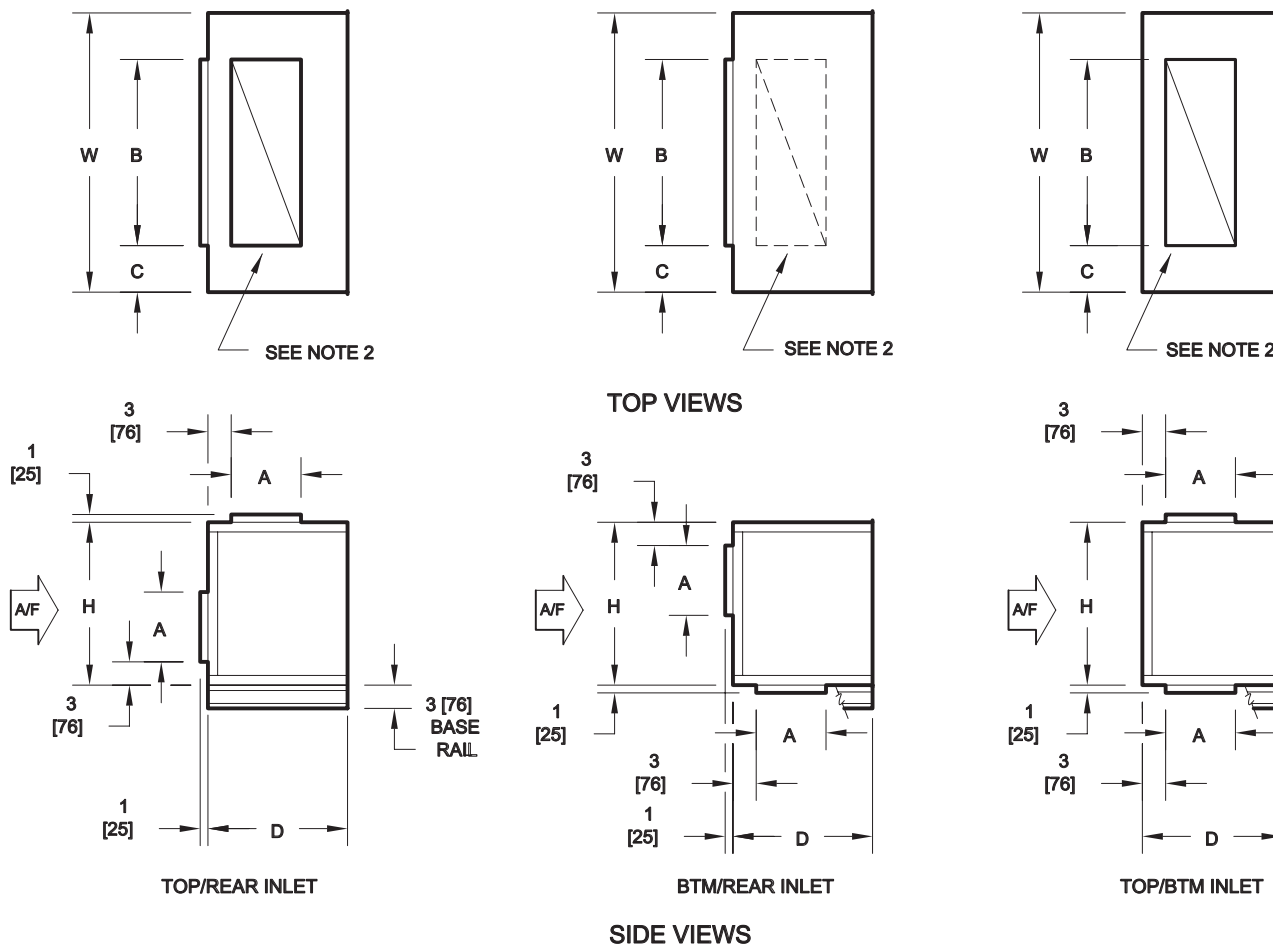

NOTES:

1. All dimensions are inches [millimeters]. All dimensions are $\pm 1/4"$ [6mm]. Metric values are soft conversion.
2. Damper drive rods are internal, located on both sides of unit.
3. Mixing box includes space for standard flat filter rack.
4. See drawing BR-001. Base rails are including with mixing box.

DIMENSIONS - in [mm]

UNIT SIZE	H	W	A	B	C	D
08	21 [533]	30 [762]	9 [229]	18 [457]	6 [152]	18 [457]
12	21 [533]	36 [914]	9 [229]	24 [610]	6 [152]	18 [457]
16	21 [533]	44 [1118]	9 [229]	30 [762]	7 [178]	18 [457]
20	21 [533]	50 [1270]	12 [305]	36 [914]	7 [178]	21 [533]
30	30 [762]	59 [1499]	12 [305]	45 [1143]	7 [178]	21 [533]
40	30 [762]	68 [1727]	15 [381]	48 [1219]	10 [254]	24 [610]

DIMENSIONAL DATA

MODEL H/V, STANDARD FLAT FILTER RACK

Drawings are not to scale and are not for installation purposes.

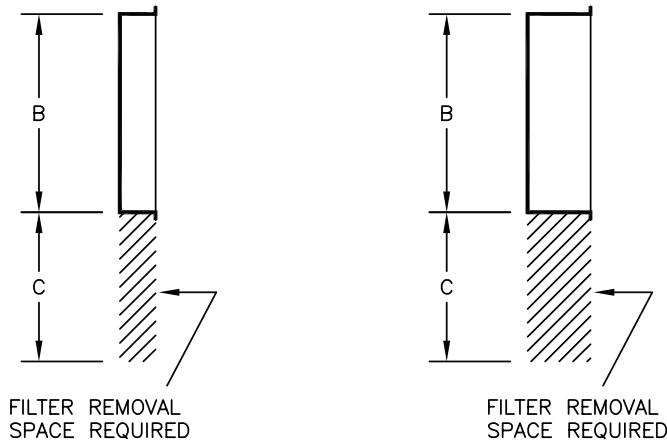

TOP VIEWS

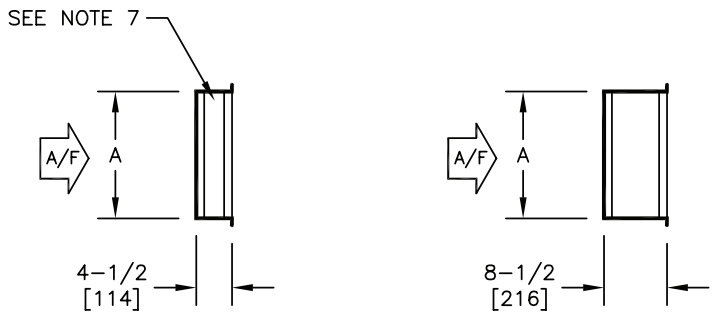

STANDARD

HIGH EFFICIENCY

SIDE VIEWS

DIMENSIONS - in [mm]

UNIT SIZE	A	B	C	QTY & SIZE FILTERS
08	16 [406]	20 [508]	20 [508]	(1) 16 X 20
12	16 [406]	25 [635]	25 [635]	(1) 16 X 25
16	16 [406]	39-1/2 [1003]	20 [508]	(2) 16 X 20
20	16 [406]	44-1/2 [1130]	25 [635]	(1) 16 X 20 (1) 16 X 25
30	25 [635]	51 [1295]	25 [635]	(2) 16 X 25 (1) 20 X 25
40	25 [635]	59 [1499]	25 [635]	(3) 20 X 25

NOTES:

1. All dimensions are inches [millimeters]. All dimensions are ±1/4" [6mm]. Metric values are soft conversion.
2. Flat filter rack may be located at unit inlet as required.
3. Standard rack will accept nominal 1" or 2" thick filters.
4. 1" duct connections space provided on entering side of rack for connection of field ductwork.
5. Hinged cover provided in both sides of externally mounted filter racks. Internal standard filter racks have pivoting bar type filter retainer.
6. See individual unit submittal drawings for location of filter rack on unit.
7. High efficiency rack will accept nominal 2" and/or 4" thick filters.
8. High efficiency rack not available with mixing box option.

UNIT DISCHARGE OPTIONS

MODEL H (HORIZONTAL)

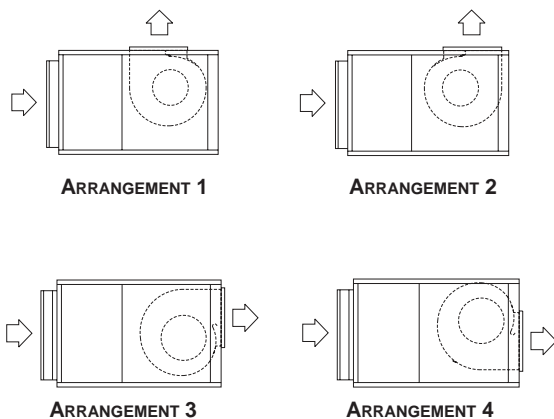

ARRANGEMENT 1

ARRANGEMENT 2

ARRANGEMENT 3

ARRANGEMENT 4

MODEL V (VERTICAL)

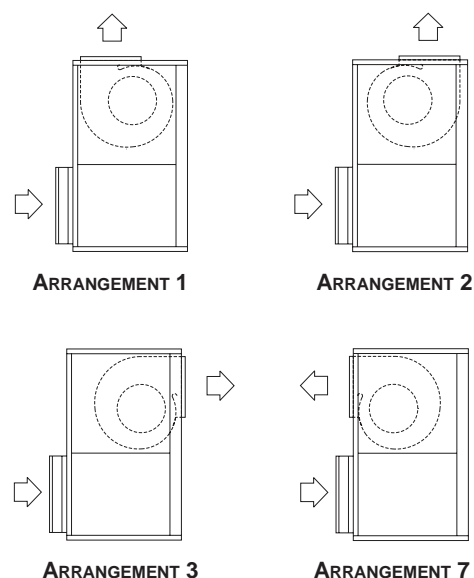

ARRANGEMENT 1

ARRANGEMENT 2

ARRANGEMENT 3

ARRANGEMENT 7

NOTES:

1. Refer to Dimensional Data for unit dimensions.
2. All drawings subject to change without prior notice.
3. Electric heaters are available in fan arrangement 3 and 4 only.

ELECTRICAL & WEIGHT DATA

MOTOR ELECTRICAL DATA

HORSEPOWER	MAXIMUM MOTOR AMPERAGE							
	VOLTAGE							
	115/1	208/1	230/1	277/1	208/3	230/3	460/3	575/3
1/3	6.3	3.5	3.2	2.6	1.7	1.5	0.8	-
1/2	7.8	4.3	3.9	3.6	2.2	2.1	1.1	0.9
3/4	10.6	5.4	5.3	5.0	3.2	3.0	1.5	1.2
1	15.0	8.3	7.5	5.5	4.0	3.6	1.8	1.4
1 1/2	-	-	-	-	5.3	5.0	2.5	1.9
2	-	-	-	-	7.0	6.4	3.2	2.5
3	-	-	-	-	9.1	9.0	4.5	3.2
5	-	-	-	-	14.2	12.8	6.4	5.2

NOTES:

- Actual motor nameplate AMPs may vary, but will not exceed values shown.
- Consult factory for applications requiring special motors.

UNIT WEIGHT DATA

COMPONENT	UNIT SIZE						
	08	12	16	20	30	40	
BASE UNIT	135 [61]	157 [71]	177 [80]	200 [90]	290 [131]	360 [163]	
MIXING BOX	46 [21]	54 [24]	65 [29]	90 [41]	105 [46]	162 [73]	
BLOW THRU ELECTRIC HEATER	42 [19]	42 [19]	42 [19]	50 [23]	55 [25]	55 [25]	
COIL ROWS	1 ROW - DRY	12 [5]	14 [6]	17 [8]	21 [10]	26 [12]	32 [15]
	1 ROW - WET	14 [6]	16 [7]	20 [9]	25 [11]	32 [15]	41 [19]
	2 ROW - DRY	17 [8]	21 [10]	26 [12]	33 [15]	42 [19]	52 [24]
	2 ROW - WET	21 [10]	26 [12]	32 [15]	42 [19]	54 [25]	69 [31]
	3 ROW - DRY	23 [10]	28 [13]	35 [16]	45 [20]	57 [26]	72 [33]
	3 ROW - WET	29 [13]	36 [16]	44 [20]	59 [27]	75 [34]	95 [43]
	4 ROW - DRY	29 [13]	35 [16]	44 [20]	57 [26]	73 [33]	91 [41]
	4 ROW - WET	37 [17]	45 [20]	56 [25]	74 [34]	96 [44]	121 [55]
	6 ROW - DRY	40 [18]	49 [22]	62 [28]	81 [37]	104 [47]	132 [60]
6 ROW - WET	52 [24]	64 [29]	81 [37]	106 [48]	138 [63]	178 [81]	

NOTE: Unit weight data is shipping weight in pounds [kilograms].

MOTOR/DRIVE WEIGHT DATA

TYPE	MOTOR HP							
	1/3	1/2	3/4	1	1 1/2	2	3	5
SINGLE PHASE	37 [17]	37 [17]	45 [20]	47 [21]	--	--	--	--
THREE PHASE	34 [15]	34 [15]	40 [18]	43 [20]	46 [21]	53 [24]	81 [37]	94 [43]

NOTES:

- Includes motor, pulleys, belts, and motor base.
- Motor/drive weight data is shipping weight in pounds [kilograms].

GUIDE SPECIFICATIONS

GENERAL

Furnish and install ENVIRO-TEC® Model H & V Belt Drive Blower Coil Units where indicated on the plans and specifications. Units shall be completely factory assembled and tested and shipped as one piece except where noted.

All units shall be capable of meeting or exceeding the scheduled capacities for cooling, heating and air delivery. All unit dimensions for each model and size shall be considered maximums.

All units shall be of "draw-thru" design with coils, fans, motor/ drive and drain pan completely contained within the unit cabinet.

Electric heat to be in the blow-thru configuration.

Units shall be cETL listed in compliance with UL/ANSI Std. 1995.

All unit coils shall meet or exceed the scheduled cooling and heating capacity, selected and rated in accordance with AHRI 410.

CONSTRUCTION

All units shall be fabricated of minimum 18 gauge galvanized steel, able to withstand a 125 hour salt spray test per ASTM B-117. Panels shall be die-formed "multi-bend" construction for optimum strength and rigidity. All exterior panels shall be (single wall insulated with 1 inch thick fiberglass insulation) (foil faced-insulated with 1" thick, 1.6 pound per cubic foot density scrim reinforced foil faced insulation), rated for a maximum air velocity of 5000 f.p.m. In addition to using adhesive complying with NFPA 90A, the insulation shall incorporate a secondary mechanical fastener attached to the unit casing wall. Adhesive as the only method of fastening the insulation to the casing is not acceptable. Maximum thermal conductivity shall be 0.24. Insulation must meet all requirements of ASTM C1071 (including C665), UL181 for erosion, and carry a 25/50 rating for flame spread/smoke developed per ASTM E-84, UL723 and NFPA 90A. All units shall have minimum 1" duct collars on discharge and return.

All access panels shall be fully insulated and attached with (standard) (hinged with lift and turn) fasteners on at least two opposite sides. No single access panel shall be larger than 30" x 36" for safety and ease of handling. No coil or drain piping or electrical connections shall pass through any access panel.

Each unit shall be furnished with a one-piece heavy gauge (IAQ galvanized steel) (IAQ stainless steel) (galvanized steel) drain pan with welded corner construction.

All units shall be provided with 9/16" diameter hanger rod holes in the top and bottom panels for "through-bolt" type suspension installation. (Rubber-in-shear) (Spring) type unit mounting vibration isolators shall be provided by the unit manufacturer.

FAN ASSEMBLY

All units shall be furnished with standard selection double inlet forward curved centrifugal blowers statically and dynamically balanced for smooth operation. All blower wheels shall have two set screws and shall be mounted on solid steel shafting rotating in ball bearings with a minimum design average life (L50) of 100,000 hours. All standard blower assemblies shall have resilient mounted cartridge type permanently lubricated ball bearings.

FAN MOTOR & DRIVE ASSEMBLY

All fan motors shall be standard NEMA design motors of the horsepower listed in the equipment schedule. All motors shall be 1750 RPM, 60 hertz (ODP) (ODP E+) single speed motors rated for continuous duty. All motors shall be reversible rotation type.

Three phase motors shall be "across-the-line" start type in 56 Frame size up through two horsepower. Three horsepower and larger shall be standard "T" frame with rigid mount.

All motors shall be mounted on an adjustable base.

All motor wiring is to be terminated in a junction box, external to the unit casing.

All fan drive assemblies shall include an adjustable pitch motor pulley, a fixed pitch blower pulley and a standard cross section "V-belt". All fan drives shall be selected at a minimum service factor of 1.2.

COILS

All unit coils shall be rated in accordance with AHRI 410. All coils shall be 1/2" O.D. seamless copper tubes with collared aluminum fins.

All tubes shall be mechanically expanded to provide an efficient bond between tube and fin. All water coils shall be provided with a manual air vent fitting to allow for coil venting. Valve core type vent fittings shall not be accepted.

All chilled water, hot water, and direct expansion (DX) coils shall have aluminum fins and 0.016" tube wall thickness. All coils shall be hydrostatically tested with air under water at 450 PSIG minimum pressure and rated for a maximum of 450 PSIG working pressure at 200°F.

GUIDE SPECIFICATIONS

All DX coils shall be provided with a distributor, and metering device (TXV) shall be field-provided. All steam coils shall have 0.025" tube wall thickness. All steam coils shall be suitable for 15 PSIG maximum operating pressure.

COIL OPTIONS

Coil casing shall be fabricated from Stainless Steel.

Provide automatic air vents, in lieu of manual air vents.

Tube wall thickness shall be 0.025" on chilled water, hot water, and direct expansion coils.

FILTER RACK ASSEMBLY

All units shall be furnished with a flat filter rack with hinged access on both sides designed to accept a 2" nominal standard sized filters. All units shall be provided with nominal 2" (throwaway) (pleated) filters factory installed. One complete set of spare (throwaway) (pleated) filters shall be provided for each unit.

FILTER OPTIONS

Unit shall have a High Efficiency filter rack suitable for a 2" (30%) and a 4" (60-65%) (80-85%) (90-95%) pleated filter.

INLET DAMPER SECTION

Where shown on the plans, the unit manufacturer shall furnish a fully insulated mixing box section (factory assembled and installed inlet damper section) to be mounted next to the unit on base rail (unit & mixing box).

The mixing box section shall include heavy gauge formed steel blade dampers in a heavy gauge steel frame with extruded vinyl blade seals and flexible metal jamb seals. Damper drive linkage shall be factory furnished and installed by the unit manufacturer. A field furnished and installed damper actuator can be mounted directly to the damper shaft.

ELECTRICAL CONTROL

The unit fan motor shall be completely factory wired to an external electrical enclosure. Each unit shall include fan control package with 24 volt control voltage. Each unit shall include motor circuit fusing, contactor, control circuit transformer and terminal strip for connection of field wiring.

A main incoming power non-fused disconnect switch shall be factory furnished and wired by the unit manufacturer for single point power connection.

ELECTRIC HEAT SECTION

Where shown on the plans, the unit manufacturer shall furnish an electric resistance heating assembly with the heating capacity, voltage and stages as shown in the schedule. The heater assembly shall be designed and rated for installation to the blower coil unit in the blow-thru configuration without the use of duct extensions or transitions between the unit and the heater assembly. The heater assembly shall be factory assembled to the air handling unit and completely factory wired. The heater/unit assembly shall be listed for zero clearance meeting all N.E.C. requirements and be cETL listed in compliance with UL/ANSI Std. 1995.

All heating elements shall be open coil design using Ni-Chrome wire mounted in ceramic insulators and housed in an insulated heavy gauge galvanized steel housing. All elements shall terminate in a machine staked stainless steel terminal secured with stainless steel hardware. The element support brackets shall be spaced no greater than 3-1/2" on center. All internal wiring shall be rated for 105°C minimum.

All heaters shall include overtemperature protection. All heaters shall include a non-adjustable airflow switch.

An incoming line power distribution block shall be provided. The power distribution block shall be designed to accept incoming power wiring capable of carrying 125% of the calculated load current.

In addition to the above, electric heaters shall include the following options:

- Main incoming power disconnect (non-fused)
- Main fusing
- Magnetic contactors wired for disconnecting operation
- Fan control package with heater interlock contacts (required for single point power connection)

NOTES

ENVIRO-TEC is a registered trademark of Johnson Controls in the United States of America and other countries.
Other trademarks used herein may be trademarks or registered trademarks of other companies.

Catalog: ET115.26-EG1 (1021) Supersedes ET115.26-EG1 (815)
© 2021 Johnson Controls P.O. Box 423, Milwaukee, WI 53201
www.enviro-tec.com

