

# CRB Series Flow Fan-Powered, VAV Terminal Units



# CRB Fan-Powered, VAV Terminals: Quiet operation, constant airflow

## Owners

CRB terminals are specifically designed for quiet operation. They also offer improved space comfort and flexibility for a wide variety of heating, ventilating, and air-conditioning (HVAC) systems. This is critical in today's buildings where occupants are placing more emphasis on indoor acoustics.

Occupants benefit from a CRB design that minimizes low-frequency (125-250 Hz) sound levels that typically dominate the space sound level.

Superior flow-measuring allows control at lower minimum cubic-feet-per-minute (CFM) values, which reduces energy costs and sound levels while maintaining comfort in the occupied space.

## Designers

Due to heightened interest in indoor air quality, many HVAC system designers are focusing on the effects of particulate contamination within a building's occupied space. Often, HVAC system noise is overlooked as a source of occupied-space contamination.

The CRB terminal is specifically designed to eliminate obtrusive fan noise from reaching the occupants, while providing constant air motion in the space.

The CRB terminal is manufactured and assembled with the FlowStar™ multi-axis, multi-point, center-averaging, airflow sensor. This sensor provides a signal to the controller enabling it to quietly and precisely measure airflow.

CRB terminals can be used in these types of applications:

- Series Fan, Cooling Only
- Series Fan, Electric Heat or Hot Water Reheat

Model CRB-EH offers electric heat and model CRB-WC offers hot-water heat. Both are available with Electronically Commutated Motor (ECM) for the ultimate in efficiency.

Model CRB terminals are available with Verasys® ZEC Series Direct Digital Control (DDC) for BACnet, or consignment controls. Verasys® ZEC DDC is specifically designed for use with CRB terminals.

Designed by experts in VAV terminal operation, these controls can accommodate a multitude of control schemes, from the most basic to the most sophisticated sequence of operation.

## Contractors

All CRB terminals are thoroughly inspected during each step of the manufacturing process, including a comprehensive pre-shipment inspection, to assure the highest quality product available. Each unit is also run-tested, before leaving the factory, to ensure trouble-free start-up.

For the ultimate in installation convenience, CRB terminals come equipped with integrated vibration isolating hanger brackets, for use with all-thread support rods, and are available with optional factory-provided and factory-installed valve packages.

A single-point power connection, and factory-calibrated controls minimize installation time. Electronic controls and electrical components are located on the same side of the casing in a flippable enclosure with side and bottom access for quick adjustment and troubleshooting.

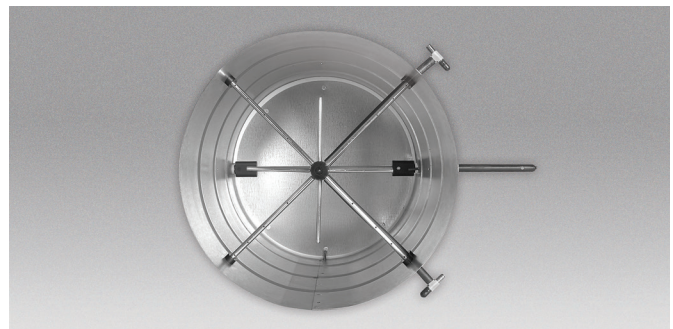

**FlowStar™ multi-axis airflow sensor**

The FlowStar™ sensor ensures accurate airflow measurement, regardless of the installation conditions. A calibration label and wiring diagram are located on the terminal for quick reference during start-up.

CRB terminals require no periodic maintenance other than optional filter replacement. If component replacement becomes necessary, the unit is designed to minimize field labor.

Top and bottom casing panels are easily removed via durable, low-profile quarter turn latches, providing easy access to the fan assembly, and motor electrical harnesses are easily accessible, allowing for quick motor and blower maintenance.



# Model CRB Construction Features

The CRB terminal incorporates many unique features. Many of these **standard** features are expensive options for other manufacturers.

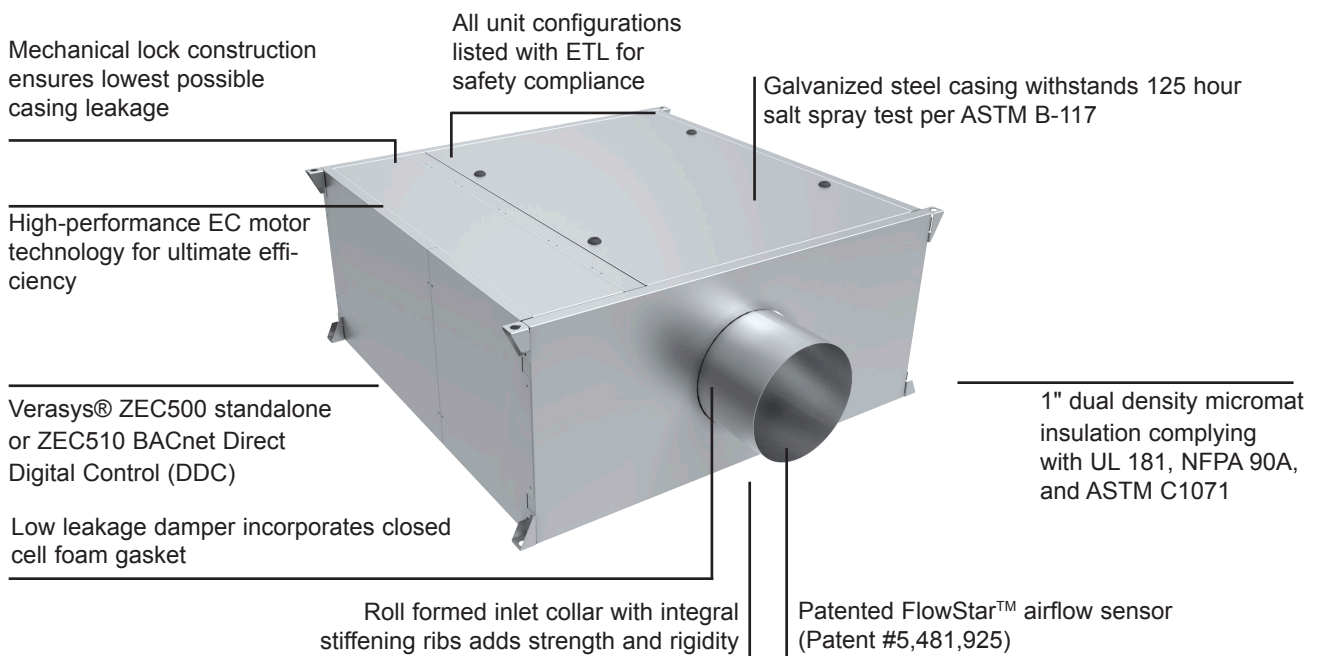
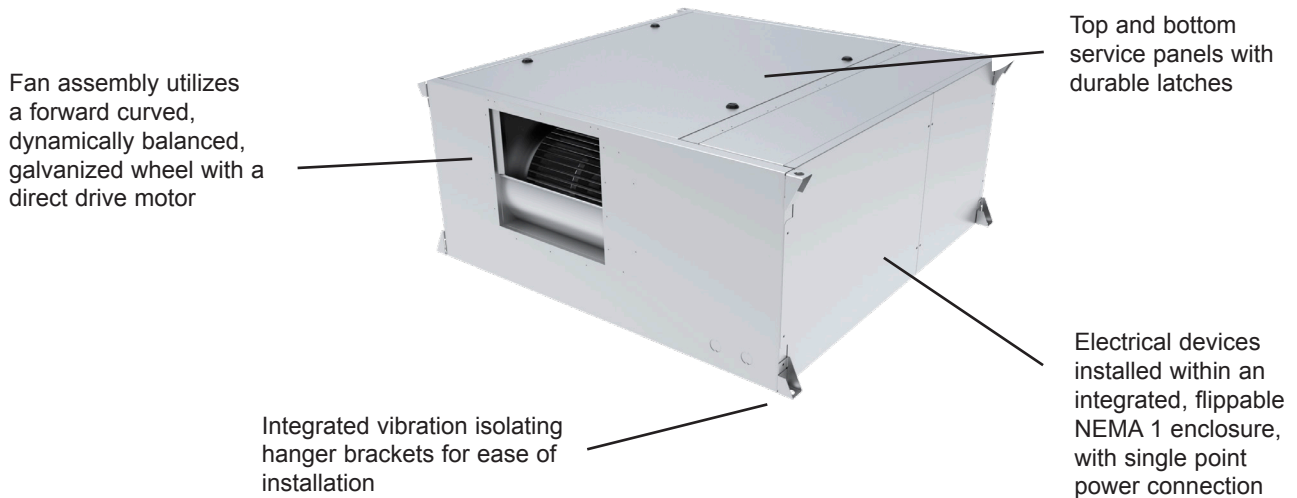

**Model CRB Cooling Only, Unit Size 10**

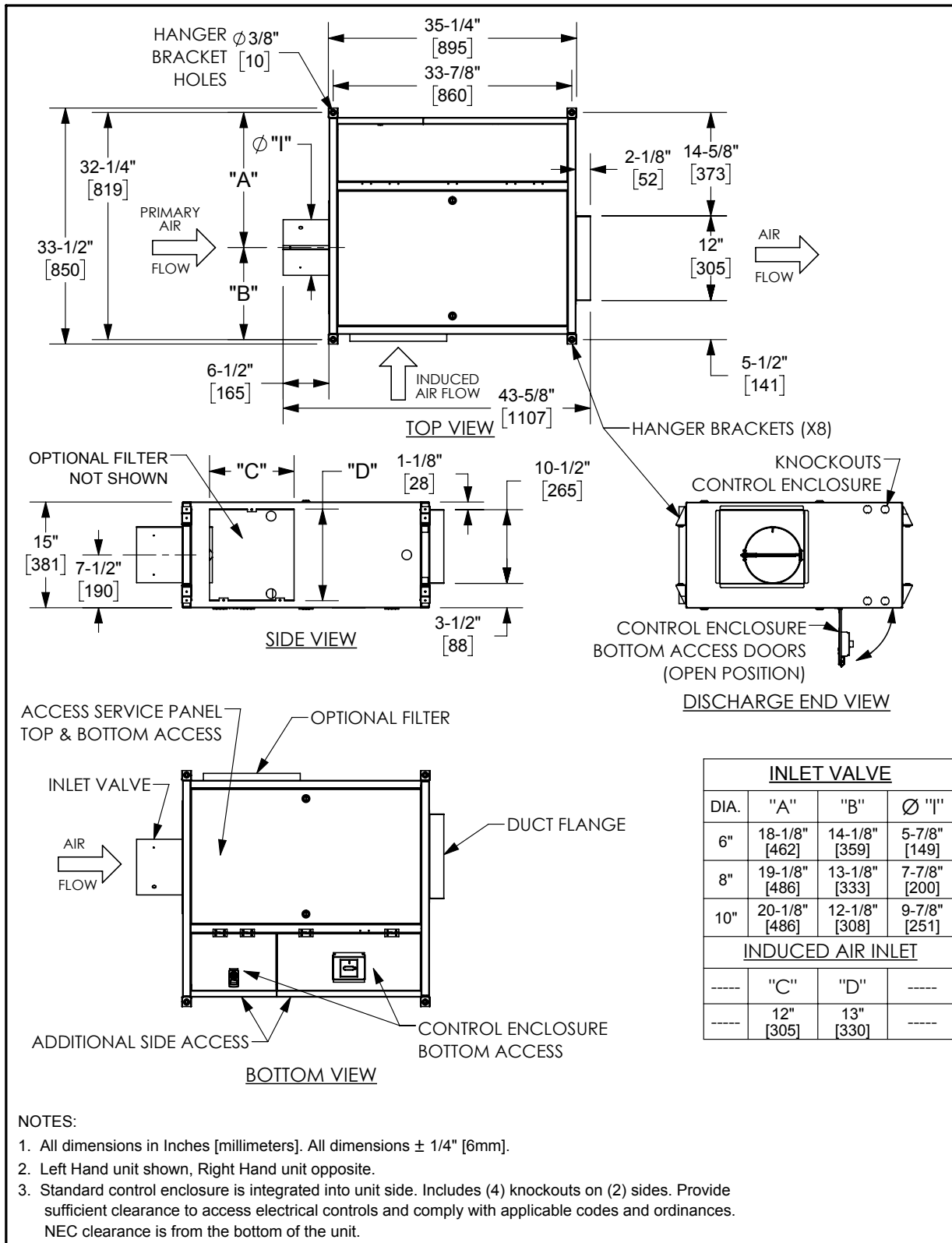

**NOTE:** Drawings are not to scale and are not for installation purposes. Unit sizes 07 and 10 are shown for illustrative purposes. For complete selection of sizes and options, visit [www.enviro-tec.com](http://www.enviro-tec.com) or contact your Enviro-Tec representative for more information. All data and dimensions are subject to change without notice.

**Model CRB Cooling Only, 90 Degree Enclosure, Unit Size 10**

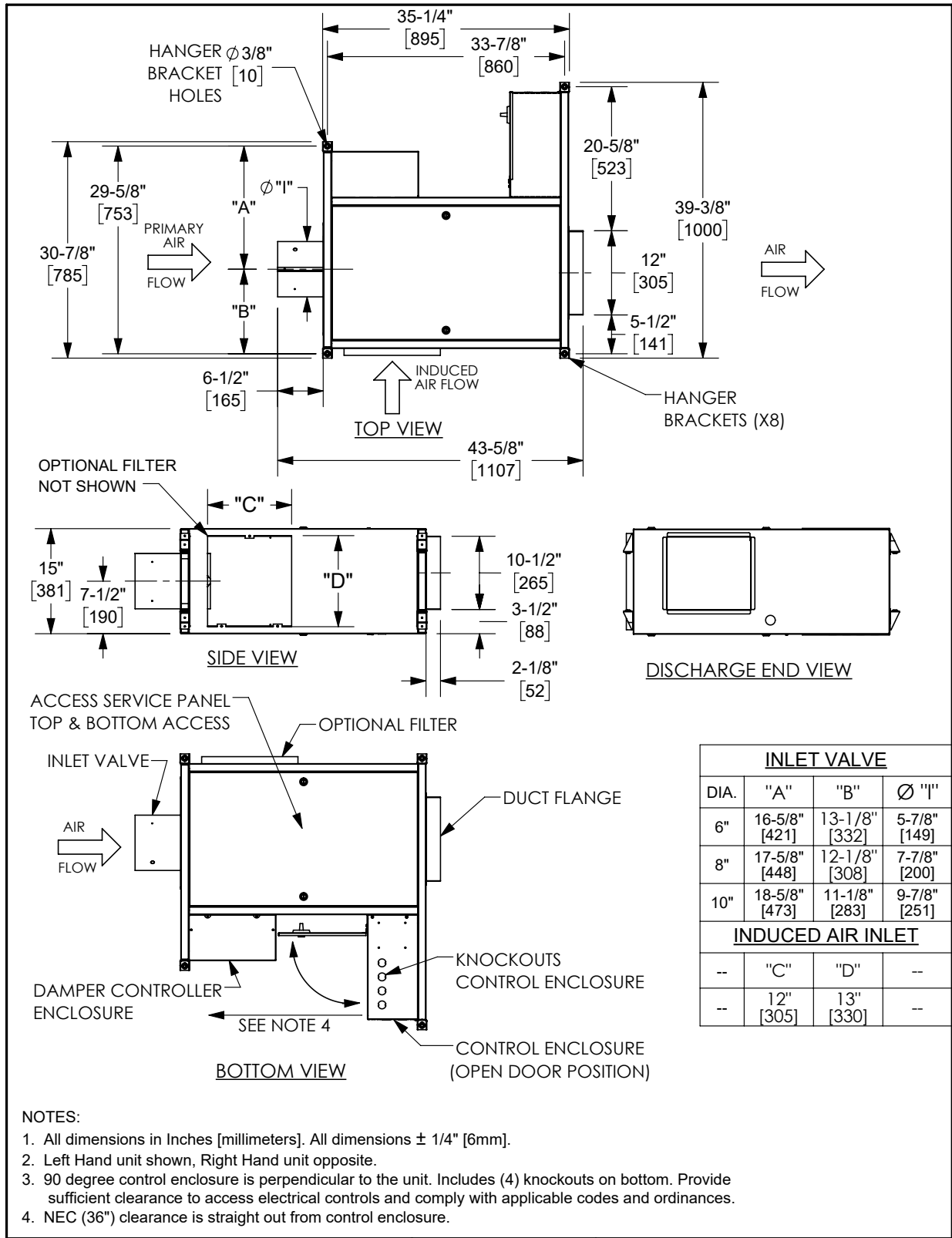

**NOTE:** Drawings are not to scale and are not for installation purposes. Unit sizes 07 and 10 are shown for illustrative purposes. For complete selection of sizes and options, visit [www.enviro-tec.com](http://www.enviro-tec.com) or contact your Enviro-Tec representative for more information. All data and dimensions are subject to change without notice.

Model CRB With Hot Water Coil, Unit Size 10

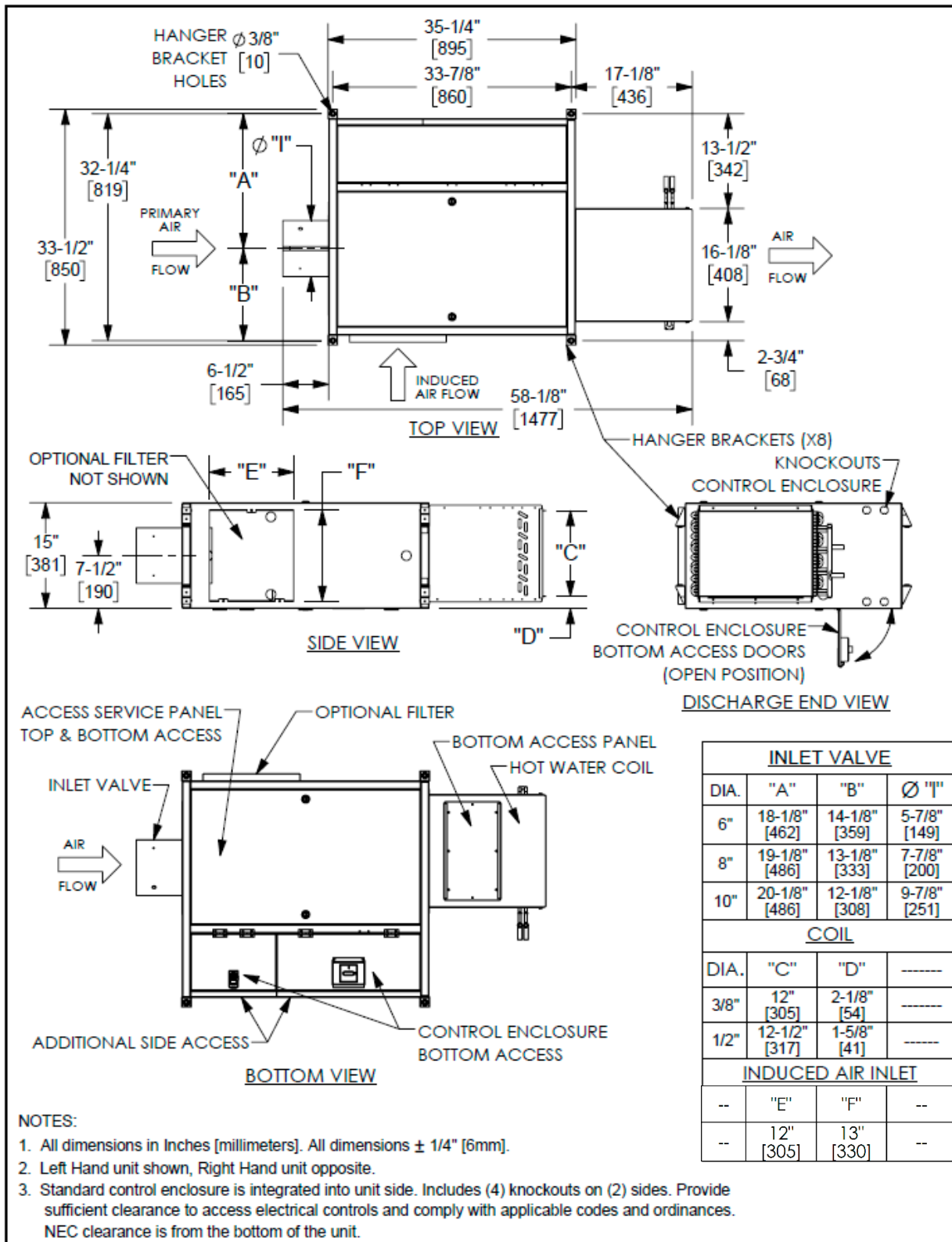

NOTE: Drawings are not to scale and are not for installation purposes. Unit sizes 07 and 10 are shown for illustrative purposes. For complete selection of sizes and options, visit [www.enviro-tec.com](http://www.enviro-tec.com) or contact your Enviro-Tec representative for more information. All data and dimensions are subject to change without notice.

**Model CRB With Hot Water Coil, 90 Degree Enclosure, Unit Size 10**

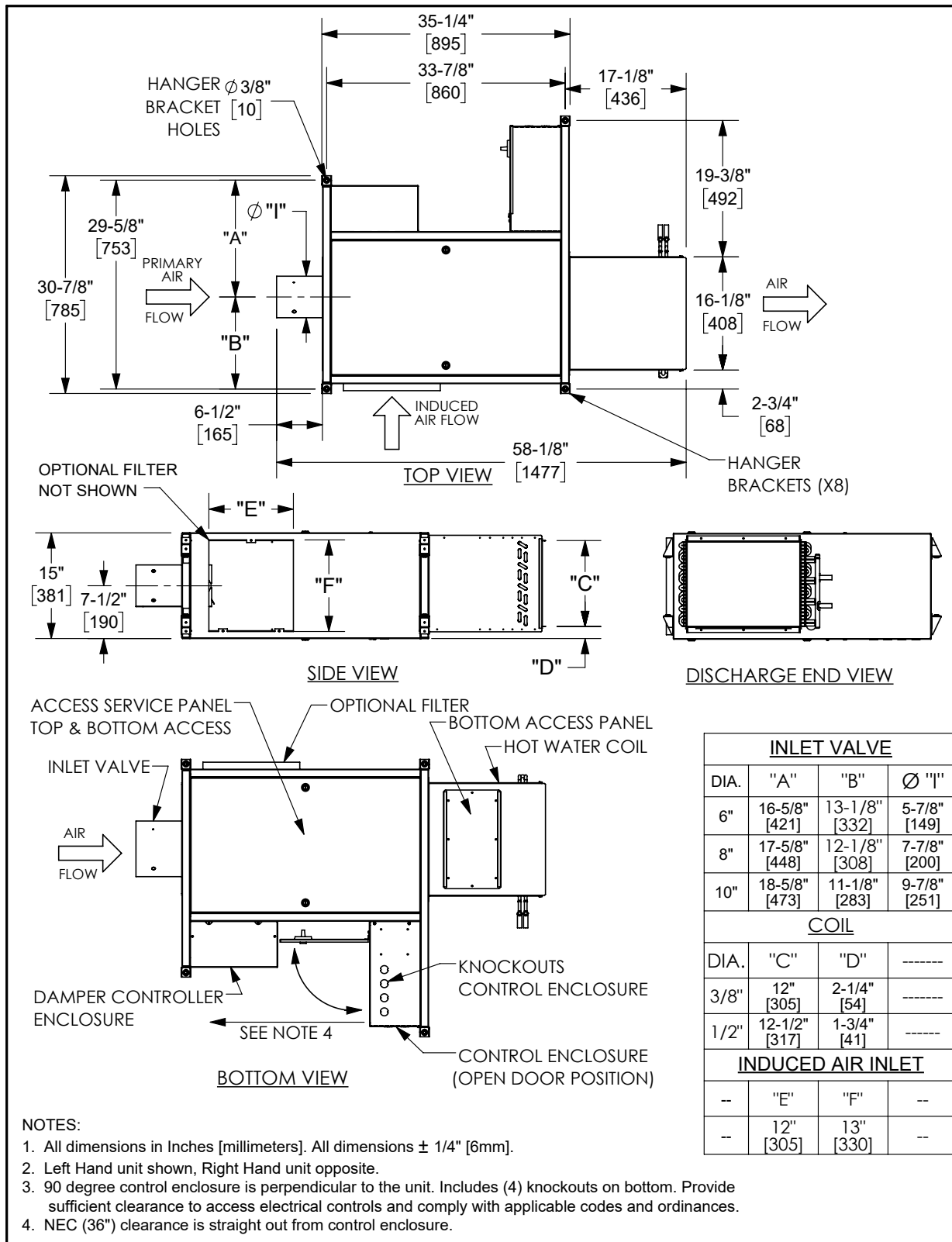

**NOTE:** Drawings are not to scale and are not for installation purposes. Unit sizes 07 and 10 are shown for illustrative purposes. For complete selection of sizes and options, visit [www.enviro-tec.com](http://www.enviro-tec.com) or contact your Enviro-Tec representative for more information. All data and dimensions are subject to change without notice.

**Model CRB With Electric Heat, Unit Sizes 07 and 10**

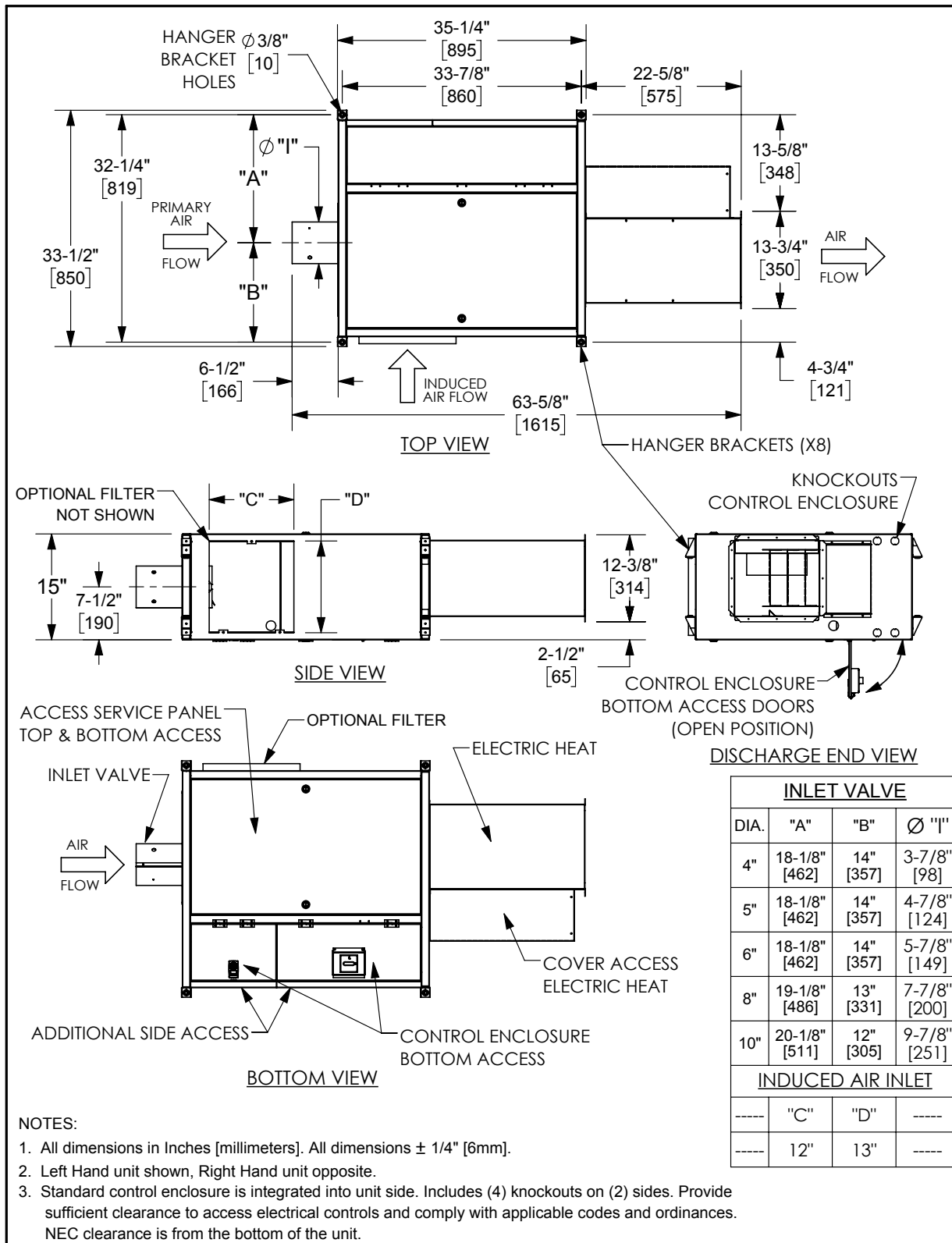

**NOTE:** Drawings are not to scale and are not for installation purposes. Unit sizes 07 and 10 are shown for illustrative purposes. For complete selection of sizes and options, visit [www.enviro-tec.com](http://www.enviro-tec.com) or contact your Enviro-Tec representative for more information. All data and dimensions are subject to change without notice.



**Model CRB With Electric Heat, 90 Degree Enclosure, Unit Sizes 07 and 10**

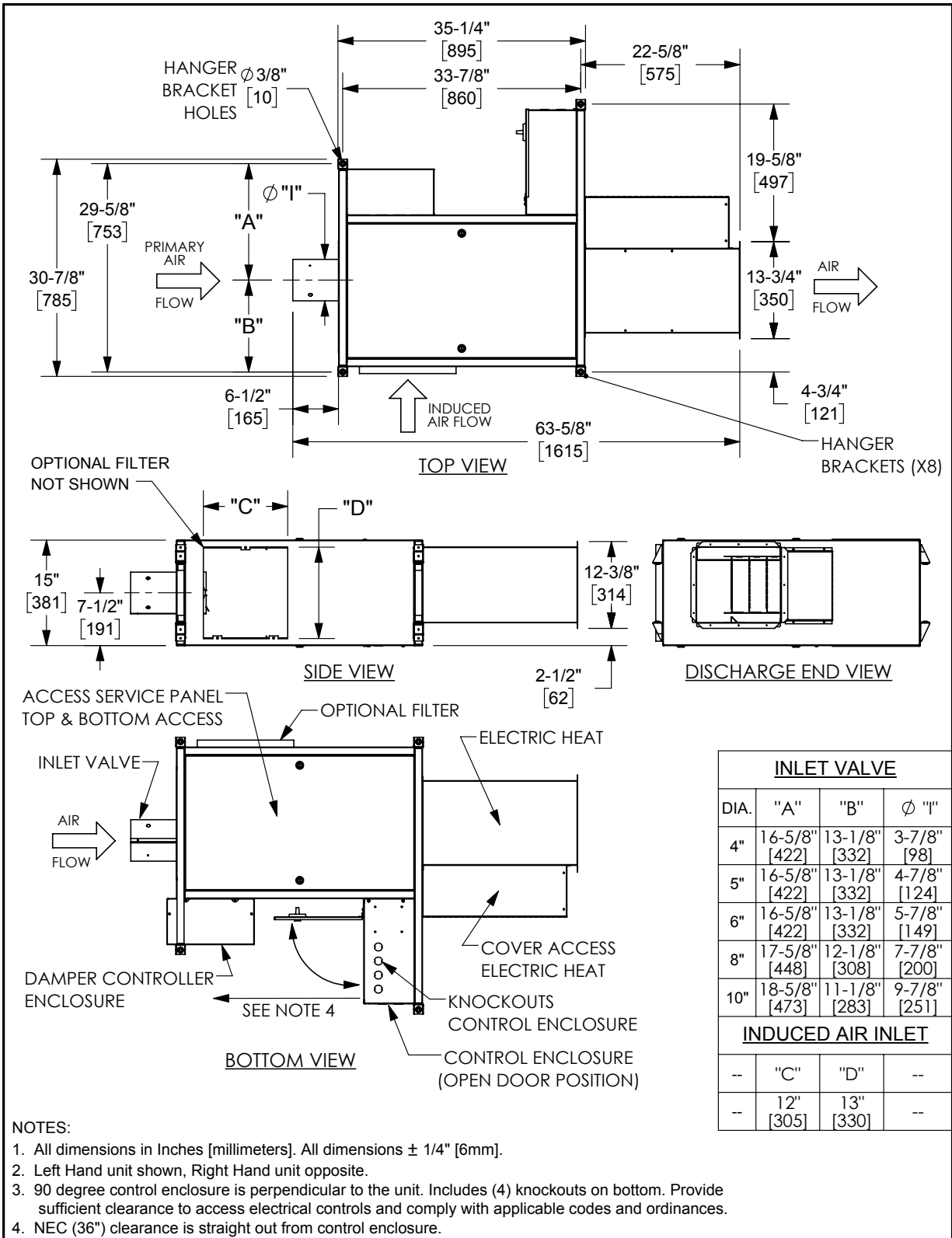

**NOTE:** Drawings are not to scale and are not for installation purposes. Unit sizes 07 and 10 are shown for illustrative purposes. For complete selection of sizes and options, visit [www.enviro-tec.com](http://www.enviro-tec.com) or contact your Enviro-Tec representative for more information. All data and dimensions are subject to change without notice.

# CRB Terminal Features

## STANDARD FEATURES

### Construction

- AHRI 880 certified and labeled
- 20 gauge galvanized steel casing and valve
- 1" dual density micromat insulation
- Full metal nosing for 1/2" and 1" insulation
- Top and bottom access panels with durable latches
- Removable motor/blower assembly
- Integrated hanger brackets with vibration isolating grommets
- Dual-layer perforated metal diffuser

### Fan Assembly

- Forward curved, dynamically balanced, direct drive, galvanized fan wheel
- 120, 208-230, and 277 volt single-phase EC motors
- Solo or Sync motor control technology
- Constant Torque or Constant Airflow Operation
- Thermally protected motor
- Vibration isolation motor mounts
- Single point wiring

### Primary Air Valve

- Embossed rigidity rings
- Low thermal conductance damper shaft
- Position indicator on end of damper shaft
- Mechanical stops for open and closed position
- FlowStar™ center averaging airflow sensor
- Balancing tees
- Plenum rated sensor tubing

### Hot Water Coils

- Coils are designed, manufactured, and tested by ENVIRO-TEC
- AHRI 410 certified and labeled
- 1, 2, 3, 4 row coils with 5/8" headers
- Tested at a minimum of 450 PSIG under water and rated at 450 PSIG working pressure at 200°F
- Left or right hand connections

### Electrical

- cETL listed for safety compliance
- Flippable integrated electrical/controls enclosure with side and bottom access
- NEMA 1 certified enclosure

### Electric Heat

- ETL assembly-listed for UL 1995 safety compliance
- Removable electric heat assembly
- Automatic reset primary and back-up secondary thermal limits
- Single point power connection
- Fusing per NEC

### Controls

- Verasys® ZEC500 Standalone or ZEC510 DDC for BACnet

## OPTIONAL FEATURES

### Construction

- 1" foil-faced fiberglass, or closed-cell foam insulation
- 1" double wall construction with 20 gauge liner (Fall 2020)
- 1" and 2" throwaway or pleated filters
- 1" and 2" tool-free filter clips
- 90-degree electrical control enclosure, NEMA 1 certified

### Fan Assembly

- 480 volt three-phase EC motor
- 120, 208-230, and 277 volt single-phase PSC motors (Fall 2020)

### Electrical

- Full unit toggle disconnect
- Inline motor fusing
- Primary and secondary transformer fusing

### Electric Heat

- Staged or Proportional with SSR
- Fused or non-fused door interlocking disconnect switches

### Configuration Tool

- Mobile Access Portal (MAP) Gateway Tool (sold separately)

### Controls

- Consignment DDC controls (factory mount and wire controls provided by others), or pneumatic

### Piping Packages

- Factory-provided and factory-mounted
- 1/2" 2 way, normally closed, two position electric motorized valves
- Isolation ball valves with memory stop
- Fixed (FC) and adjustable (PICV) flow control devices
- Y-Strainers, P/T ports, 18" flexible hose
- Floating point modulating control valves