

**OBSOLETE PRODUCT**

Stock ID: CAT-ETVT

August, 2002

©2002 Environmental Technologies, Inc.  
Largo, Florida USA

**ENVIRO-TEC®**

**ETVT II**

**Variable Volume  
Variable Temperature  
Control System**



**ENVIRONMENTAL TECHNOLOGIES, INC.**

ENGINEERING FOR EXCELLENCE

**TABLE OF CONTENTS**

---

ETVT-II SYSTEM OVERVIEW . . . . . 4

SYSTEM CONTROL UNIT . . . . . 6

ZONE CONTROLLERS . . . . . 8

BYPASS CONTROLLER . . . . . 11

SDR TERMINAL UNIT SPECIFICATIONS . . . . . 12

SGX TERMINAL UNIT SPECIFICATIONS . . . . . 14

WDDCMON MONITOR/SETUP SOFTWARE. . . . . 16

SYSTEM DESIGN GUIDELINES . . . . . 21

SAMPLE APPLICATION . . . . . 24

ETVT-II SYSTEM GUIDE SPECIFICATIONS . . . . . 26

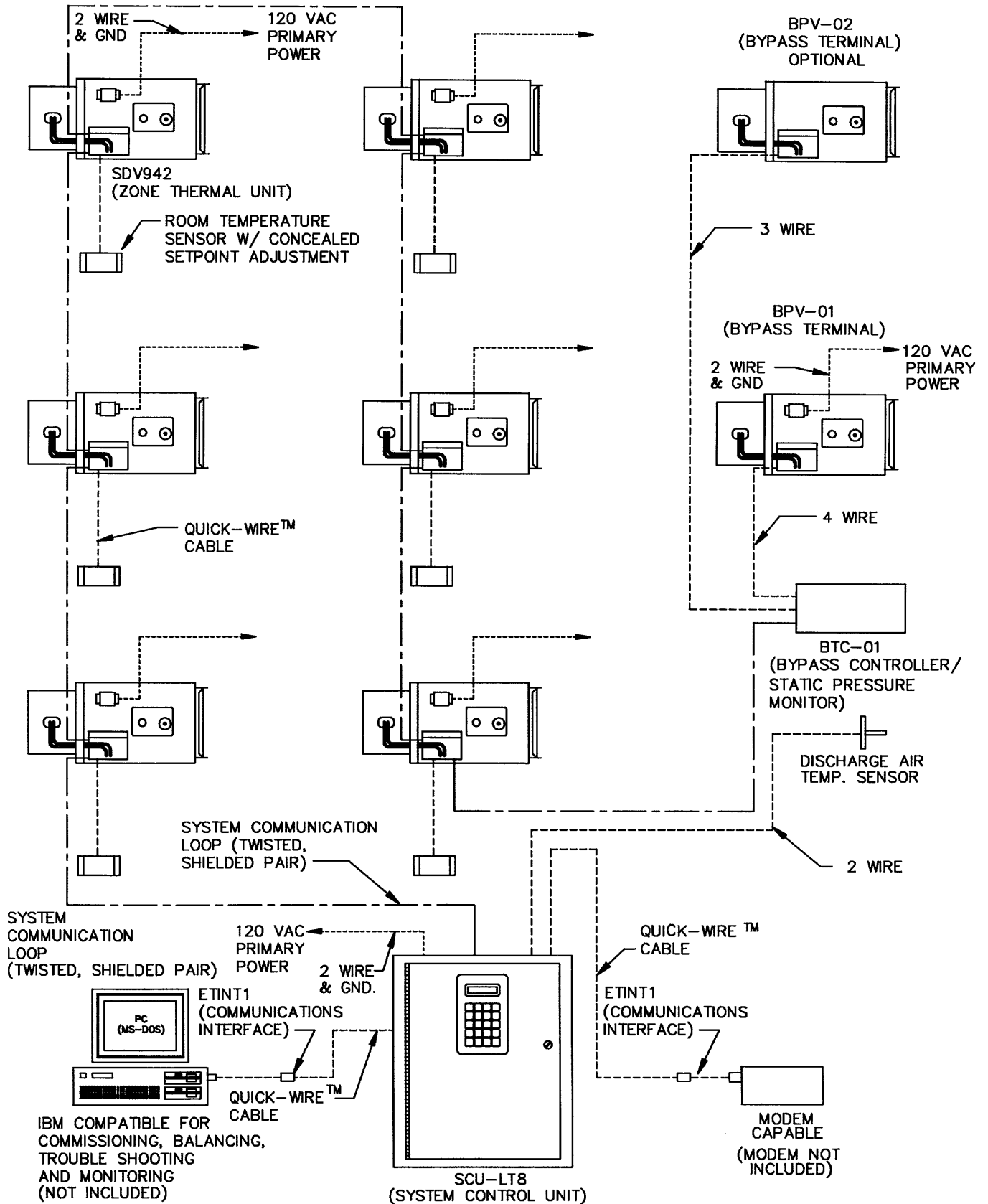

# ETVT-II SYSTEM OVERVIEW

---

## **Direct Digital Zone Control**

The Environmental Technologies Variable Temperature (ETVT-II) control system provides Direct Digital Control (DDC) of multi-zone heating and cooling systems. The ETVT-II system components are designed to provide the advantages of intelligent, microprocessor-based comfort control at a very reasonable cost.

The use of DDC controllers allows the entire system to communicate essential information between the controllers so that the system is able to make the most efficient use of the HVAC unit's heating and cooling capacity to achieve optimum temperature control.

The ETVT-II system allows the building manager to easily monitor the entire system and, if desired, modify its operation as building usage or requirements change.

## **Pressure Independent Control**

The ETVT-II zone terminal controllers feature pressure independent operation, automatic changeover, and proportional, integral, and derivative (PID) temperature control.

## **Fan Powered Terminals**

In addition to standard single duct terminal units, the ETVT-II system is suitable for use with Enviro-Tec's entire line of fan powered, hydronic heat, and electric reheat terminal units. This provides a degree of flexibility that was previously only possible with expensive high-end DDC systems.

## **Commercial/Industrial Duty Equipment**

Even though the ETVT-II system is designed to be cost effective in low tonnage installations, it uses Enviro-Tec's high quality commercial grade pressure independent DDC controllers and terminal units for unsurpassed functionality and reliability.

All ETVT-II controllers, terminal units, and computer programs are designed and manufactured by Enviro-Tec. This sole sourcing yields reliable, consistent operation and provides fast solutions to potential HVAC system design problems.

## **Small or Large Building Use**

A typical ETVT-II installation consists of a System Control Unit (SCU), 1 to 64 VAV terminals, a pressure relief (bypass) terminal unit, and a static pressure (bypass) terminal controller. However, up to 99 SCU's can be linked together for larger projects and monitored from a central personal computer (PC).

## **Direct Expansion or Hydronic Systems**

The ETVT-II system is frequently applied with direct expansion rooftop and split systems which require maintaining a constant DX coil airflow. The ETVT-II pressure relief (bypass) system maintains supply duct static pressure and coil CFM. This system consists of a standalone bypass terminal controller and one or more bypass terminal units.

## **Central HVAC Unit Control**

The System Control Unit (SCU) provides the HVAC unit control portion of the system. It communicates with all of the zone terminal controllers in the system to determine the building heating and/or cooling requirements. Based on these requirements and its discharge temperature sensor, the SCU controls the HVAC unit by activating and deactivating relays which control the HVAC unit fan with up to seven stages of heating and/or cooling.

Output relays are field definable, providing maximum flexibility and backup output devices for smaller systems.

## **Operator Interface**

The System Control Unit (SCU) includes a Liquid Crystal Display / Keypad operator's panel which can be used to configure and monitor all zone controllers in the system.

The communications interface socket allows a Windows® compatible computer to be connected to the system using a factory supplied cable. A powerful, user friendly computer program allows configuration and monitoring of the SCU and all of the zone controllers in the system directly or remotely via an optional 2400 baud modem.

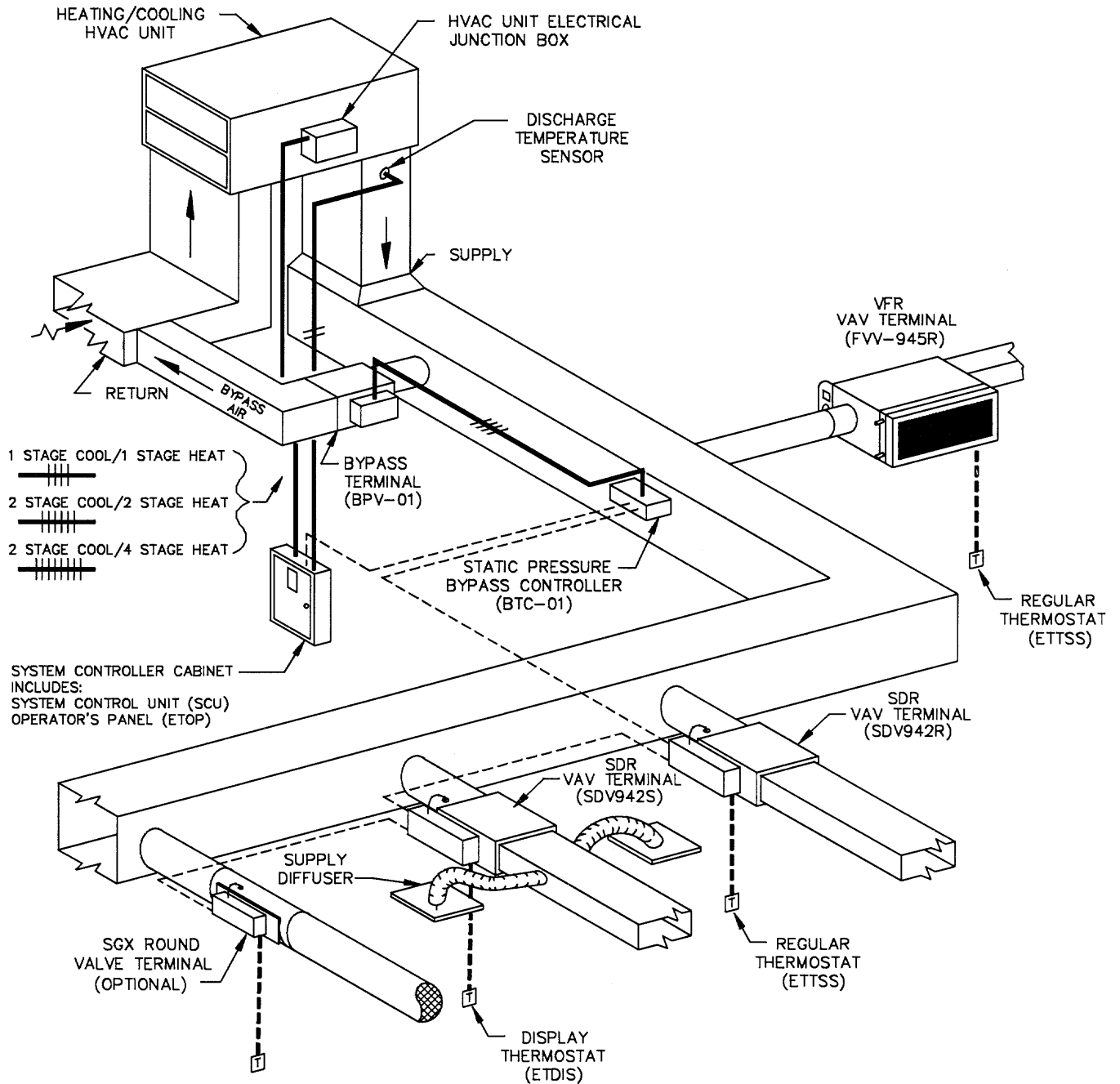

- COMMUNICATION CABLE, TWISTED SHIELDED PAIR WITH DRAIN BY OTHERS (MUST BE IN "DAISY CHAIN" SERIES)
- QUICK-WIRE™ CABLE
- || 2 WIRE CABLE BY OTHERS
- |||| 4 WIRE CABLE BY OTHERS
- ||||| 6 WIRE CABLE BY OTHERS
- |||||| 8 WIRE CABLE BY OTHERS

## SYSTEM CONTROL UNIT (SCU)



The System Control Unit (SCU) monitors each zone temperature. Its control logic determines the central air conditioning unit mode status, either heating, cooling, or ventilation.

The SCU's battery-backed real time clock / calendar with automatic leap-year and daylight savings time adjustments schedules occupied (daytime) and unoccupied (night setback or setup) periods for each day of the week and a special holiday schedule.

An electronic duct temperature sensor measures the discharge air temperature from the HVAC unit. The SCU meets zone load demands while avoiding low suction temperatures and coil frosting while in the cooling modes with built in off-cycle timers.

The SCU protects a heat pump from a manual reset nuisance tripout on high pressure by sensing a high supply air temperature condition and cycling off mechanical heating for a preset off-cycle period.

Configuration and monitoring of all of the controllers in the system is done at the SCU. Up to 99 System Control Units can be connected together on their own communications network. With 64 terminals per SCU, one ETVT-II system could serve an installation with over 6,000 terminal units and 99 central air handling units.

A Windows® compatible PC on-site or connected by modem allows an owner operator, system designer, installer, or service technician to set up all air terminals and system operating parameters including zone temperature setpoints and to perform system check-out and diagnostics.

### Sequence of Operations

The System Control Unit provides eight field definable output control relays to interface with the HVAC unit. By sequencing these relays, the SCU will call for fan operation, up to 7 stages of heating, or up to 7 stages of cooling, heat pump changeover, or any combination of 8 outputs.

Once every minute, the SCU communicates with each of the zone controllers connected on its communications network to determine the total heating and/or cooling requirements of the building. A zone vote weighting system determines optimum central heating or cooling operation.

Configuration settings in the SCU control the minimum and maximum duration of the cycles to limit excessive cycling of the HVAC unit. A preset ventilation period between heating and cooling changeover allows the ductwork to be purged saving energy and protecting the HVAC unit.



The SCU determines the required mode of operation. It turns individual heating or cooling stages on or off to maintain the appropriate discharge air temperature. The turn-on and turn-off temperatures for each individual stage of heating or cooling can be configured separately. A programmable anticycle function for each output ensures that the cooling compressor(s) will not be short-cycled during normal operation or after a power failure.

The SCU schedules up to fourteen programmable occupied periods per week (two per day) and 16 programmable holiday periods. When the system is in unoccupied mode, a command is sent to all the VAV units on the network to revert to their unoccupied mode settings. If the SCU is in unoccupied mode and all units are within the programmed temperature limits, the HVAC unit will be shut down.

In the occupied mode, when all zones are satisfied, the unit fan operates continuously to maintain ventilation and air motion. All terminal units are set at minimum CFM operation. The nominal air motion creates greater comfort and improves dilution of stale air with outside air from the central HVAC unit.

**Component Designations**

**SCU-LT8: The System Control Unit features:**

- Two line by 16 character liquid crystal and 20-key operator's panel
- Communications interface cable
- Monitor/access software
- Transformer
- Disconnect
- Line block
- Heating and cooling manual override switches
- Terminal strip for connection to AHU
- Painted enclosure with hinged access door
- Eight field definable relays for control of any combination of fan, heating, cooling and changeover outputs

**System Control Unit  
Dimensional Data**

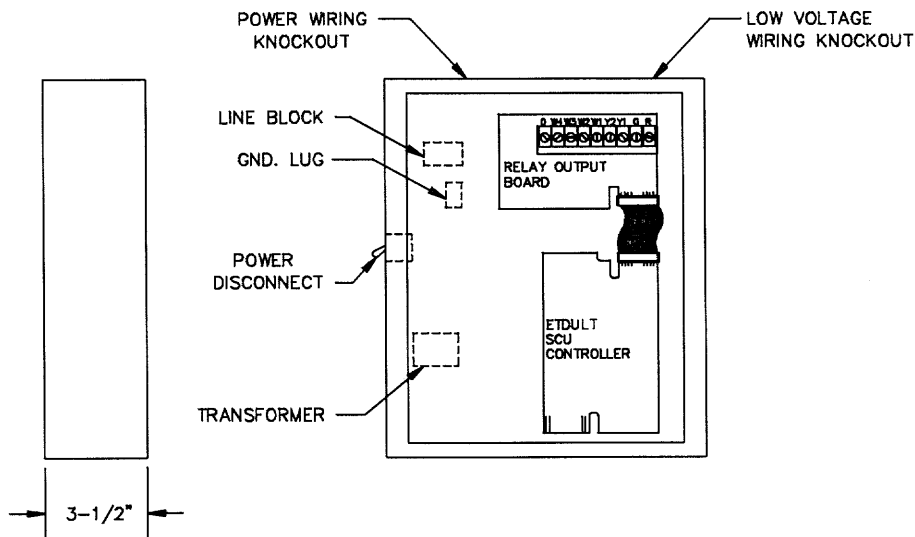
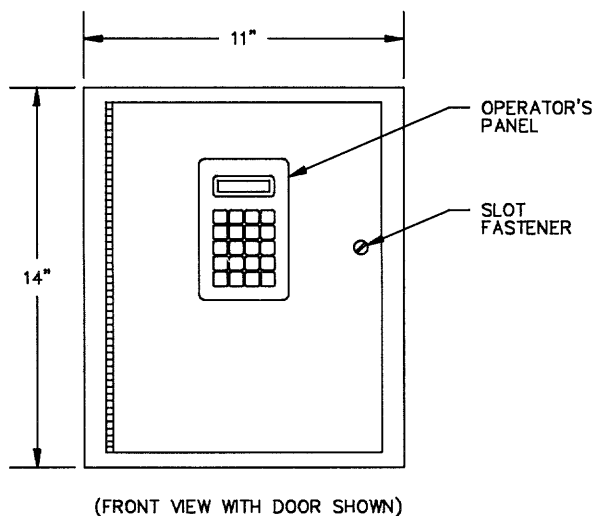

# ZONE CONTROLLERS



The DDC zone controller is microprocessor based and intelligently performs proportional, integral, and derivative (PID) control of the terminal functions including heating or cooling votes, damper operation, and optional fan and/or electric heat to provide optimum zone comfort.

The zone controller provides pressure independent VAV flow control and automatic changeover operation. Each zone terminal unit includes a regular thermostat or a Smart-Stat™ display thermostat. Both thermostats include a zone temperature sensor, communications interface connector, and an unoccupied mode override switch.

The standard thermostat includes a temperature setpoint control knob. The Smart-Stat™ includes a 4-digit green LED display, a 6-position keypad, and a locking cover. The Smart-Stat™ lets the occupant see:

- Cooling setpoint
- Heating setpoint
- Duct temperature
- Room temperature
- Unit CFM

## Pressure Independent Operation

Each zone terminal controller contains Enviro-Tec's exclusive flow compensated differential pressure transducer. In a VAV system, the static pressure in the duct will change whenever any zone controller opens or closes its damper. This flow transducer enables the zone controller to calculate how much air is being supplied to the zone so that it can keep the airflow constant even when the static pressure in the duct is changing. This is called pressure independent operation. Pressure independent means that each zone is not affected by every other zone in the system and prevents constant temperature swings and noisy breathing of the system. In addition, the zone controller can accurately maintain minimum ventilation airflow levels to ensure adequate ventilation while maximizing energy efficiency.

## Stand-Alone Operation

Although much of the power of the ETVT-II system lies in the ability of the controllers to communicate their heating and cooling needs to the System Control Unit, the zone controllers are designed to provide stand-alone operation if required. Because of this capability, if one part of the system loses power or malfunctions, the rest of the system can still operate normally. Each zone controller keeps track of the last time it communicated with the SCU; if a controller hasn't communicated within the previous 90 seconds, it will automatically switch to its occupied (daytime) operation and continue to operate normally. The zone controllers do not rely on the SCU to tell them whether the HVAC unit is currently supplying hot air or cold air since each controller has its own electronic duct temperature sensor. This sensor allows the controller to determine the temperature of the supply air, compare that temperature with the zone temperature, and then decide whether to use the supply air for heating or cooling.

## PID Temperature Control

In order to provide optimum temperature control, the zone controllers use a proportional, integral, and derivative (PID) control algorithm.

This means that the controller has the ability to intelligently determine the exact amount of cooling or heating required by the zone.

PID control is a common-sense approach to temperature control. The proportional factor means that more heating or cooling is supplied as the zone temperature gets further away from set-point. The integral factor adds time into the equation, which means that if a zone has been too hot or too cold for a period of time, the heating or cooling is increased or decreased until the proper level is achieved. The derivative factor means that the zone controller will compensate for rapid temperature changes, such as a large group of people entering a previously unoccupied conference room.



### Configuration Settings

Each zone terminal controller has flexibility in terms of application and operation. The configuration settings are modified using the WDDCMON Monitor/Setup Software (see page 16) and are retained by the controllers non-volatile memory in the event of a power failure.

The zone terminal controller has programmable setpoints for occupied and unoccupied control modes including heating and cooling maximum and minimum airflow. Vote weighting factors for heating and cooling permit certain controllers to be given a higher or lower priority than others in determining the operation of the HVAC unit. An override time setting is also provided which allows a controller to request activation of the HVAC unit if the switch at the controller's thermostat is depressed. Actual override time is totaled and stored in each zone.

Units with reheat capability, including fan induction terminals, can be configured to operate independently based on local demands for heat without requiring the HVAC unit to be in heat mode. During occupied operation, fan terminals can be configured to provide heat without requiring activation of the HVAC unit's fan. Fan terminal motors are rated for air temperature of 122°F. If using series fan terminals with a changeover central system, care must be taken to limit supply air temperature to 120°F.



Smart-Stat™



Standard Thermostats

**Component Designations**

**SDV942R:**

Single duct terminal with digital electronic controller, electric actuator, inlet duct temperature sensor, transformer, sheet metal enclosure, and regular thermostat. Available box sizes are: 4", 5", 6", 8", 10", 12", 14", 16", 19", and 22".

**SDV942S:**

Same as SDV942R but with Smart-Stat™ thermostat with 4-digit LED display and keypad.

**SDV945R:**

Same as SDV942R with additional outputs to support either 2-stages of electric heat, 2-position hot water heat, or floating modulating hot water heat.

**SDV945S:**

Same as SDV945R but with Smart-Stat™ thermostat with 4-digit LED display and keypad.

**FVV945R:**

Variable volume (parallel) fan powered supply unit with digital electronic controller, electric actuator, inlet duct temperature probe, transformer, fan relay, sheet metal enclosure, and regular thermostat.

**FVV945S:**

Same as FVV945R but with Smart-Stat™ thermostat with 4-digit LED display and keypad.

**FCV945R:**

Constant volume (series) fan powered supply unit with digital electronic controller, electric actuator, inlet duct temperature probe, transformer, fan relay, sheet metal enclosure, and regular thermostat.

**FCV945S:**

Same as FCV945R but with Smart-Stat™ thermostat with 4-digit LED display and keypad.

**QW25, QW50:**

Standard 25 and 50 foot plenum rated Quick-Wire™ cables. Custom lengths are available.

**QW25N, QW50N:**

Standard 25 and 50 foot non-plenum rated Quick-Wire™ cables. Custom lengths are available.

**Bypass Controller and Terminal:** Most ETVT-II systems are utilized with a low cost constant volume HVAC unit which must deliver a constant volume of air in order to maintain acceptable unit operation. Therefore, a pressure relief system consisting of a bypass terminal controller and from one to three bypass terminal units are used to provide constant air flow to the central HVAC unit.

The bypass controller includes a static pressure transducer for monitoring and controlling the duct static pressure. The controller is completely standalone so that it is not dependent upon any other controllers for proper operation. The bypass terminal communicates with the System Control Unit so that the static pressure can be monitored.

### Sequence of Operations

One to three bypass terminal units are operated in parallel to maintain constant duct static pressure. If the duct static pressure rises above the setpoint, the bypass dampers will modulate open to lower the pressure and maintain the

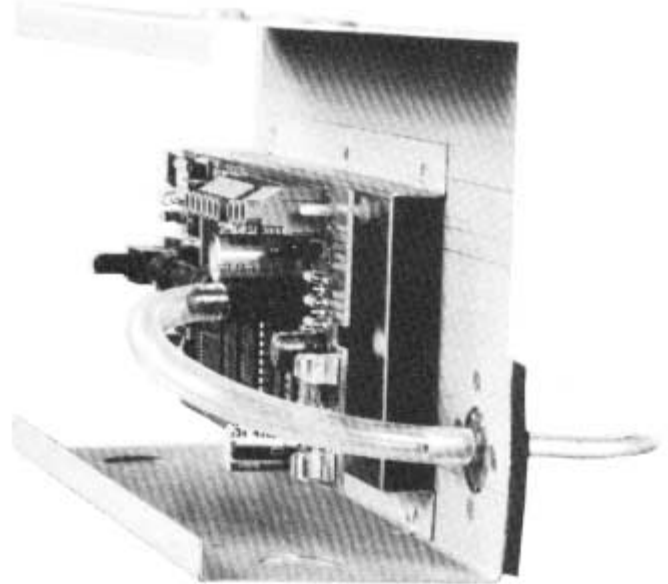

setpoint. If the duct static pressure drops below the setpoint, the bypass dampers will modulate closed to increase the pressure and maintain the setpoint.

## Component Designations

### BTC-01:

Digital electronic static pressure controller with static pressure transducer, sheet metal enclosure, and static pressure probe. Each bypass system requires one BTC-01.

### BPV-01:

Single duct bypass terminal unit (SDR) with electric actuator, terminal strip, transformer, and control enclosure. Available box sizes are: 4", 5", 6", 8", 10", 12", 14", 16", 19", and 22". The transformer in the BPV-01 provides operating power to the BTC-01 and, if used, the BPV-02 bypass terminal unit or units. Each bypass system requires a BPV-01.

### BPV-02:

Same as BPV-1 but does not include transformer. For use as an additional bypass damper in systems with multiple bypass dampers. Each multiple bypass system requires one or two BPV-02s.

# SDR TERMINAL UNIT SPECIFICATIONS

Both the zone and the bypass terminal units use the Enviro-Tec SDR terminal units. These are available in sizes ranging from 4" to 22" and feature durable construction, low leakage, and excellent acoustical characteristics. Inlet collars for all box sizes are round (except for sizes 19 and 22 which are rectangular). The SDR has an insulated rectangular duct connection.

UNIT SIZE	W	H	L	A	J	X	Y
4	10"	10"	11"	10 1/2"	3 7/8"	8 3/4"	8 3/4"
5	10"	10"	11"	10 1/2"	4 7/8"	8 3/4"	8 3/4"
6	10"	10"	11"	6 1/2"	5 7/8"	8 3/4"	8 3/4"
8	12"	10"	11"	6 1/2"	7 7/8"	10 3/4"	8 3/4"
10	14"	12 1/2"	13"	6 1/2"	9 7/8"	12 3/4"	11 1/4"
12	16"	15"	13"	6 1/2"	11 7/8"	14 3/4"	13 3/4"
14	20"	17 1/2"	17"	6 1/2"	13 7/8"	18 3/4"	16 1/4"
16	24"	17 1/2"	17"	6 1/2"	15 7/8"	22 3/4"	16 1/4"
19	30"	17 1/2"	11"	8"	28 1/4" x 13 7/8"	28 3/4"	16 1/4"
22	34"	17 1/2"	11"	8"	32 1/4" x 15 7/8"	32 3/4"	16 1/4"

NOTE: Sizes 19 and 22 have rectangular inlets.

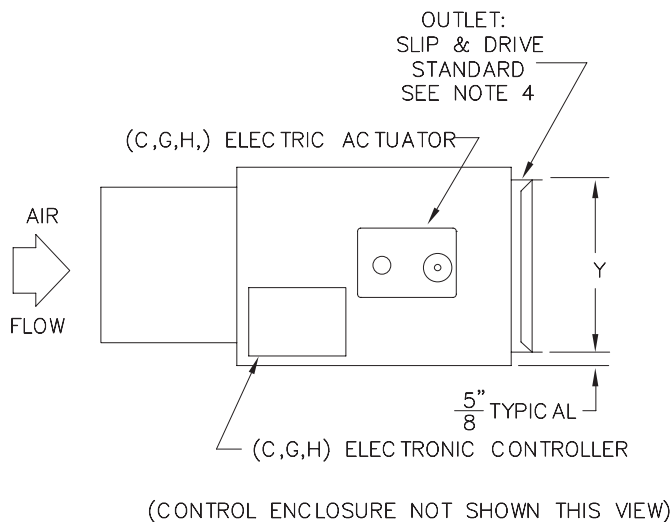
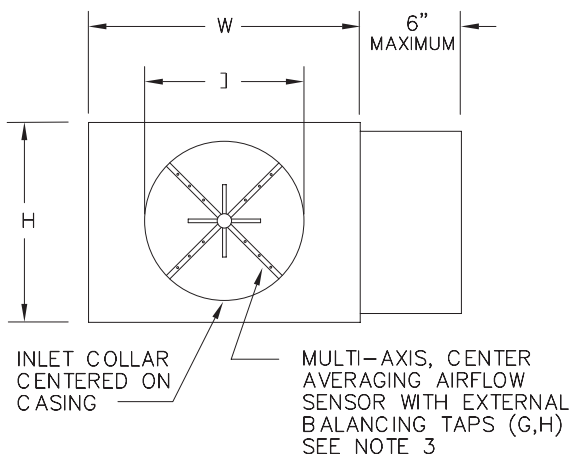
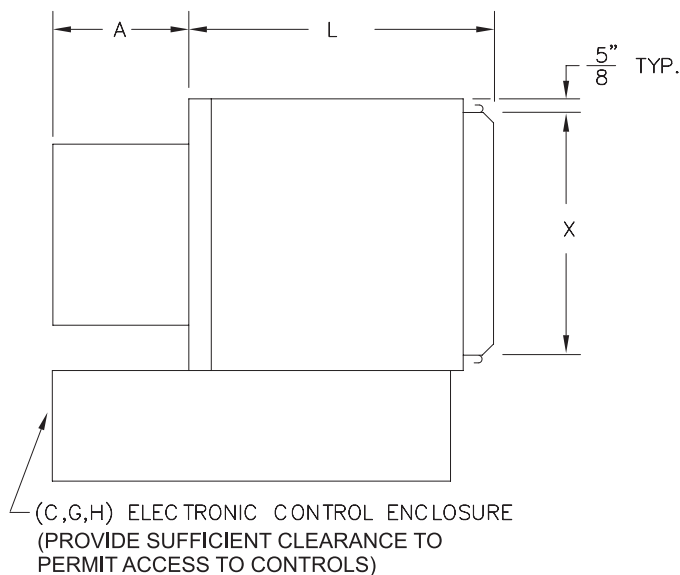



# SDR GENERAL SELECTION DATA

TERMINAL SIZE	CFM	Min. ΔPs Model SDR/ SDR-SA	DISCHARGE NOISE CRITERIA (NC)						RADIATED NOISE CRITERIA (NC)		
			0.5" ΔPs		1.0" ΔPs		3.0" ΔPs		0.5" ΔPs	1.0" ΔPs	3.0" ΔPs
			Model SDR	Model SDR-SA	Model SDR	Model SDR-SA	Model SDR	Model SDR-SA	Model SDR & SDR-SA	Model SDR & SDR-SA	Model SDR & SDR-SA
4	100	.01	--	--	--	--	--	--	--	--	--
	150	.01	--	--	20	--	28	20	--	--	--
	200	.01	--	--	24	--	33	27	--	--	24
	250	.01	22	--	27	23	37	32	--	--	28
5	100	.01	--	--	--	--	--	--	--	--	--
	200	.01	--	--	--	--	25	--	--	--	--
	300	.01	--	--	20	--	28	22	--	--	20
	350	.01	--	--	20	--	27	20	--	--	23
6	200	.02	--	--	--	--	23	--	--	--	--
	250	.03	--	--	--	--	24	--	--	--	--
	300	.04	--	--	--	--	25	20	--	--	20
	350	.06	--	--	--	--	24	--	--	--	22
	450	.10	--	--	20	--	28	22	--	--	25
	550	.14	--	--	24	20	32	27	--	23	29
8	300	.01	--	--	--	--	25	--	--	--	--
	400	.02	--	--	--	--	23	--	--	--	21
	500	.03	--	--	--	--	24	--	--	--	24
	600	.04	--	--	--	--	25	--	--	--	25
	800	.08	--	--	--	--	27	20	--	--	27
	1000	.12	--	--	20	--	28	23	--	20	29
10	600	.01	--	--	--	--	28	--	--	--	27
	800	.03	--	--	--	--	27	--	--	--	27
	1000	.04	--	--	--	--	27	--	--	--	27
	1200	.06	--	--	--	--	29	23	--	--	28
	1400	.08	--	--	--	--	29	23	--	--	28
	1600	.11	--	--	20	--	29	24	--	22	29
12	800	.01	--	--	--	--	24	--	--	--	28
	1100	.03	--	--	--	--	24	--	--	--	29
	1400	.04	--	--	--	--	25	--	--	--	30
	1700	.06	--	--	--	--	27	22	--	20	31
	2000	.09	--	--	--	--	29	24	--	21	32
	2300	.12	--	--	--	--	29	24	--	22	33
14	1100	.01	--	--	--	--	24	--	--	--	25
	1500	.03	--	--	--	--	25	--	--	--	27
	1900	.04	--	--	--	--	25	20	--	--	28
	2300	.07	--	--	--	--	27	22	--	--	29
	2700	.09	--	--	--	--	28	23	--	20	30
	3100	.12	--	--	--	--	28	24	--	23	32
16	1600	.02	--	--	--	--	--	--	--	--	28
	2100	.03	--	--	--	--	23	--	--	--	30
	2600	.04	--	--	--	--	28	23	--	--	30
	3100	.07	--	--	--	--	28	23	--	--	32
	3600	.09	--	--	--	--	29	25	--	22	33
	4100	.12	--	--	--	--	32	28	--	24	34
19	2500	.06	--	--	20	--	28	20	--	25	34
	3000	.09	--	--	20	--	29	23	20	27	35
	3500	.13	--	--	20	--	29	24	23	28	37
	4500	.21	--	--	20	--	32	27	23	31	38
	5500	.32	--	--	20	--	33	29	27	34	42
	6500	.44	20	--	23	--	35	32	30	36	43
22	4000	.06	--	--	22	--	30	25	--	27	37
	5000	.10	--	--	23	20	32	27	20	29	39
	6000	.14	--	--	24	22	33	28	21	32	39
	7000	.20	20	--	24	22	33	29	24	32	40
	8000	.25	22	--	25	22	34	30	27	33	40

**NOTES:**

- Minimum ΔPs is the static pressure difference between the terminal inlet and discharge with the damper wide open.
- Performance data obtained from tests conducted in accordance with ARI Standard 880.
- NC values are based on assumptions outlined in ARI Standard 885.
- Dash (--) indicates NC level less than 20.
- Discharge NC values based upon:
  - 5' lined duct (12" x 12") with 1" thick fiberglass insulation
  - Maximum 300 CFM per diffuser
  - 10 feet from source
  - 6' lined 8" flex duct at diffuser
  - 5000 ft<sup>3</sup> space
- Radiated NC values based upon:
  - 3' deep ceiling cavity
  - 5000 ft<sup>3</sup> space
  - 5/8" thick - 35 lb./ft<sup>3</sup> mineral fiber ceiling tile
  - 10 feet from source

# SGX TERMINAL UNIT SPECIFICATIONS ENVIRO-TEC®

As an option, the Enviro-Tec SGX terminal unit may be used when round inlet and discharge are specified. These are available in sizes ranging from 4" to 16" and feature durable construction, low leakage, and excellent acoustical characteristics.

UNIT SIZE	D
6	5 7/8"
8	7 7/8"
10	9 7/8"
12	11 7/8"
14	13 7/8"
16	15 7/8"

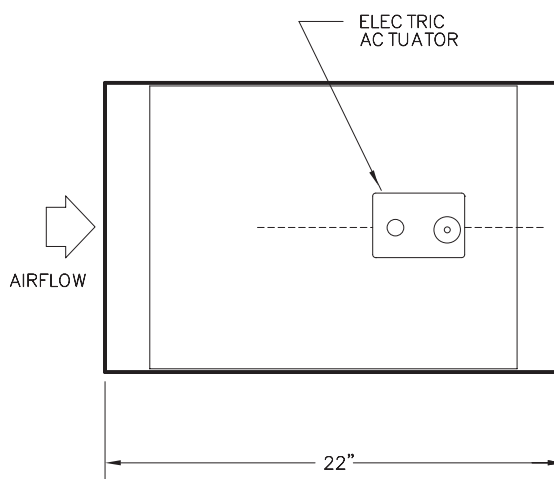
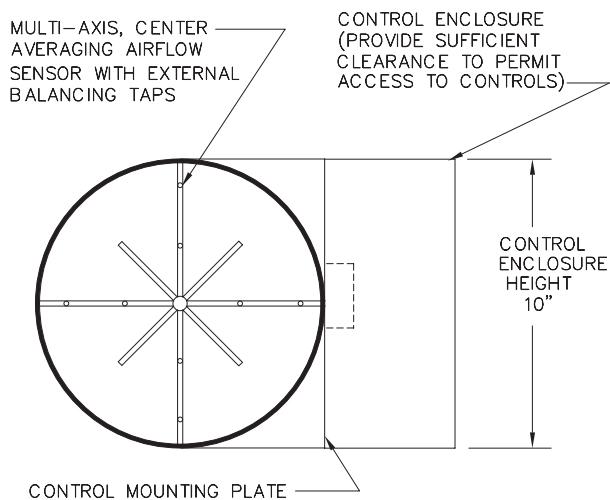
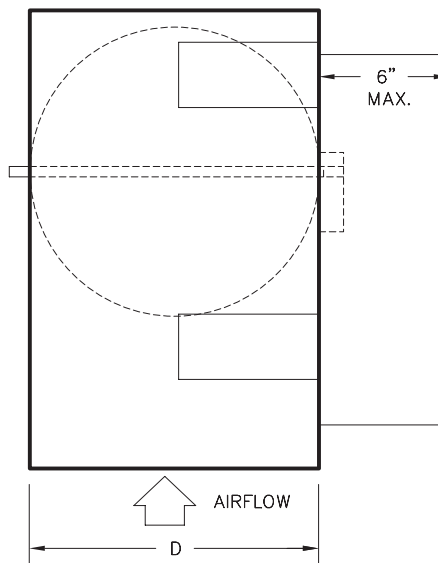

TERMINAL SIZE	CFM	Min. ΔPt	DISCHARGE NOISE CRITERIA (NC)				RADIATED NOISE CRITERIA (NC)			
			MIN ΔPs	MIN ΔPs + .75"	MIN ΔPs + 1.5"	MIN ΔPs + 3"	MIN ΔPs	MIN ΔPs + .75"	MIN ΔPs + 1.5"	MIN ΔPs + 3"
6	275	.13	26	34	41	49	22	27	33	38
	315	.18	28	35	42	50	22	28	33	38
	350	.22	30	36	44	51	23	29	34	39
	390	.26	31	37	45	52	24	30	35	39
	430	.33	32	38	45	53	26	30	35	39
	470	.39	34	39	46	54	28	32	36	40
	510	.46	35	40	47	55	30	33	36	41
8	490	.13	30	35	41	49	20	25	29	35
	560	.17	30	36	42	49	21	25	29	35
	630	.21	30	37	44	50	22	25	30	36
	700	.26	31	38	45	51	23	26	31	37
	770	.32	33	39	46	52	23	28	32	37
	840	.38	36	40	47	53	23	29	33	38
	905	.45	38	41	48	54	23	30	35	39
10	765	.13	31	35	42	49	20	23	29	35
	870	.17	33	36	43	50	20	24	29	35
	980	.21	34	38	44	51	20	25	30	36
	1090	.26	35	39	45	52	20	26	31	37
	1200	.32	36	40	45	52	22	27	32	37
	1310	.38	37	41	46	53	24	28	33	38
	1415	.44	38	42	47	54	26	29	34	39
12	1100	.13	29	34	40	47	20	24	30	36
	1255	.17	31	35	42	50	21	25	32	37
	1415	.21	32	36	44	53	22	26	33	37
	1570	.26	34	38	46	56	24	27	34	38
	1725	.31	35	39	47	56	25	28	34	39
	1885	.38	36	40	48	56	28	30	35	40
	2040	.44	37	41	49	57	29	32	36	41
14	1500	.13	32	38	43	49	25	25	31	37
	1710	.17	34	39	44	50	26	27	33	38
	1925	.21	35	40	45	51	27	29	35	40
	2140	.26	36	41	47	52	28	31	37	41
	2355	.31	38	42	47	53	28	32	37	42
	2570	.38	40	43	48	54	29	34	38	44
	2780	.44	41	45	49	55	30	35	39	45
16	1945	.12	29	34	41	54	20	31	40	48
	2225	.16	31	36	43	54	23	32	40	49
	2500	.20	33	37	45	55	25	33	41	50
	2780	.26	34	39	47	55	27	34	42	50
	3060	.31	35	40	48	56	30	35	43	52
	3335	.37	36	42	49	58	33	36	43	53
	3615	.43	38	43	50	59	36	38	44	54

**NOTES:**

- Minimum ΔPs is the static pressure difference between the terminal inlet and discharge with the damper wide open.
- Performance data obtained from tests conducted in accordance with ARI Standard 880.
- NC values are based on assumptions outlined in ARI Standard 885.
- Discharge NC values based upon:
  - 5' lined duct (12" x 12") with 1" thick fiberglass insulation
  - Maximum 300 CFM per diffuser
  - 10 feet from source
  - 6' lined 8" flex duct at diffuser
  - 5000 ft<sup>3</sup> space
- Radiated NC values based upon:
  - 3' deep ceiling cavity
  - 5000 ft<sup>3</sup> space
  - 5/8" thick - 35 lb./ft<sup>3</sup> mineral fiber ceiling tile
  - 10 feet from source



# WDDCMON Monitor/Setup SFTW.

Included with every ETVT-II system is the ETVT-II Monitor/Setup computer software (WDDCMON), which allows access to the System Control Unit and all of the zone terminal controllers connected on the communications network. This program can be used on almost any Windows® compatible computer with a serial communications port. The computer is connected to the System Control Unit's operator's panel or any zone thermostat using a supplied interface cable.

WDDCMON provides a viewport to the internal operations of the ETVT-II controllers (System Control Unit, Zone Terminal Controllers, and Bypass Controllers) and also allows the configuration settings in the controllers to be modified as desired. System operation and maintenance are greatly simplified by the ability to monitor and configure the entire system from one central location without interruption of system operation.

WDDCMON is designed to be very easy to use, and all of the program functions can be performed with straightforward keyboard operations. In addition, all configuration settings are made in common engineering units (such as CFM, °F, and minutes or seconds) instead of using binary numbers or some other controller specific format.

Pictured on the following pages are just a few of the WDDCMON program screens as they appear during actual program operation. They give summary information about the controllers on the network, provide specific information about the System Control Unit operation, allow the SCU occupied schedule to be set, and allow the zone Terminal Controller Configurations to be modified.

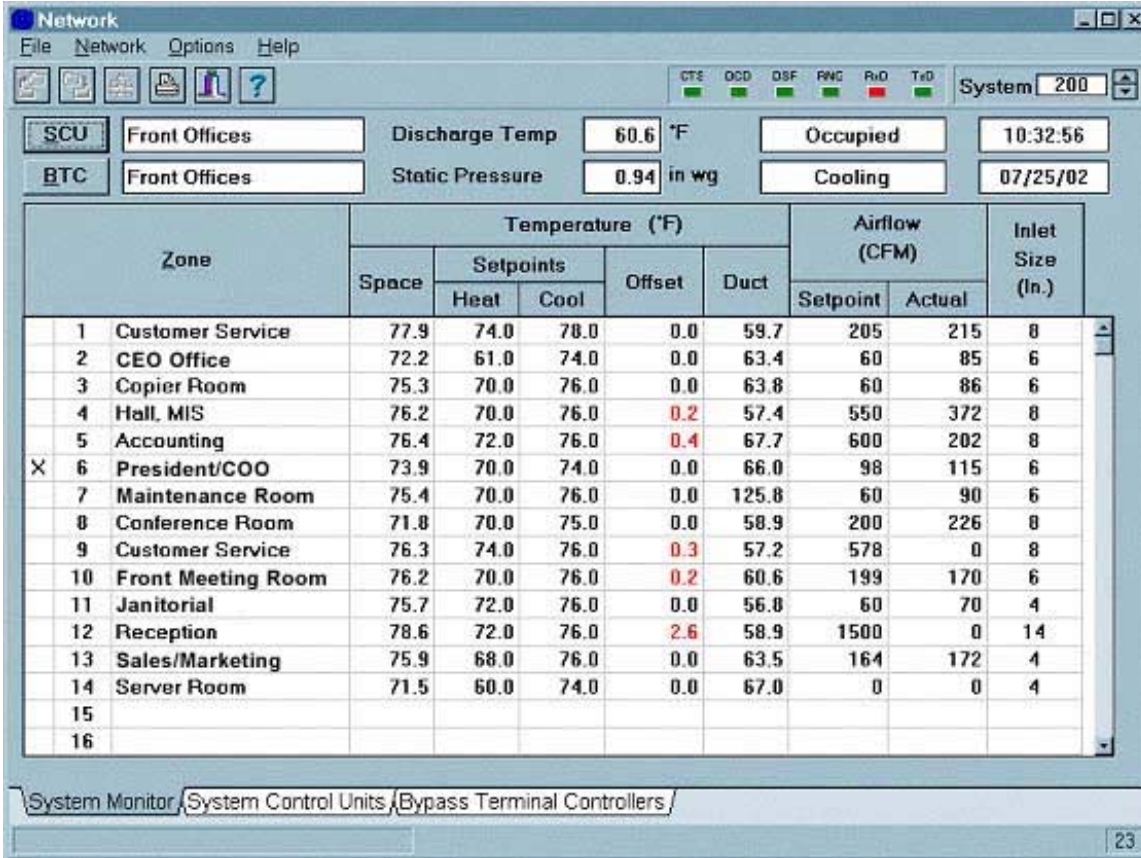

The screenshot shows the 'Network' software interface. At the top, there is a menu bar (File, Network, Options, Help) and a toolbar. Below the toolbar, there are status indicators for GTE, OCD, DSF, RNG, RxD, and TxD, along with a 'System' dropdown menu set to '200'. The main display area is divided into several sections:

- SCU Section:** Shows 'Front Offices' selected. Discharge Temp is 60.6 °F. Status is 'Occupied'. Time is 10:32:56.
- BTC Section:** Shows 'Front Offices' selected. Static Pressure is 0.94 in wg. Status is 'Cooling'. Date is 07/25/02.
- Table Section:** A table with columns for Zone, Space, Temperature (°F) (Setpoints: Heat, Cool, Offset, Duct), Airflow (CFM) (Setpoint, Actual), and Inlet Size (In.).

Zone	Space	Temperature (°F)				Airflow (CFM)		Inlet Size (In.)	
		Heat	Cool	Offset	Duct	Setpoint	Actual		
1	Customer Service	77.9	74.0	78.0	0.0	59.7	205	215	8
2	CEO Office	72.2	61.0	74.0	0.0	63.4	60	85	6
3	Copier Room	75.3	70.0	76.0	0.0	63.8	60	86	6
4	Hall, MIS	76.2	70.0	76.0	0.2	57.4	550	372	8
5	Accounting	76.4	72.0	76.0	0.4	67.7	600	202	8
X 6	President/COO	73.9	70.0	74.0	0.0	66.0	98	115	6
7	Maintenance Room	75.4	70.0	76.0	0.0	125.8	60	90	6
8	Conference Room	71.8	70.0	75.0	0.0	58.9	200	226	8
9	Customer Service	76.3	74.0	76.0	0.3	57.2	578	0	8
10	Front Meeting Room	76.2	70.0	76.0	0.2	60.6	199	170	6
11	Janitorial	75.7	72.0	76.0	0.0	56.8	60	70	4
12	Reception	78.6	72.0	76.0	2.6	58.9	1500	0	14
13	Sales/Marketing	75.9	68.0	76.0	0.0	63.5	164	172	4
14	Server Room	71.5	60.0	74.0	0.0	67.0	0	0	4
15									
16									

At the bottom of the window, there is a breadcrumb trail: 'System Monitor / System Control Units / Bypass Terminal Controllers /' and a page number '23'.



**System Control Unit - 200 (Front Offices)**

File Network Options Help

CTS OGD OSF PWC R/D T/D System 200

**Zone Controllers**

Number Responding: 14  
 Cooling Demand: 340  
 Heating Demand: 0  
 Overriding Zone: 0

**Air Temperature**

Discharge Temperature: 60.6 °F  
 Return Temperature: 73.7 °F  
 Outside Temperature: N/A °F

**Scheduling**

Date: 07/25/02  
 Time: 10:39:25  
 Day: Thursday

**Cycle Timers**

Cooling to Heating: 00:00:00  
 Heating: 00:00:00  
 Heating to Cooling: 00:00:00  
 Cooling: 00:02:02

**Output Control**

**Operation Mode**

Occupied Cooling

**AHU Relay Control**

1	Fan	ON	00:00	min
2	Cooling 1	ON	00:00	min
3	Cooling 2	ON	00:00	min
4	Heating 1	OFF	00:00	min
5	Heating 2	OFF	00:00	min
6	Heating 3	OFF	00:00	min
7	Heating 4	OFF	00:00	min
8	Auxiliary 2	OFF	00:00	min

Net BTC Zone Help

Lock

Monitor / Schedule / Auxiliary Schedule / Configuration / AHU Control / Test Variables / QA

16

**System Control Unit - 200 (Front Offices)**

File Network Options Help

CTS OGD OSF PWC R/D T/D System 200

**Set Time Clock**

Time: 10:41:16  
 Date: 07/25/02  
 Day: Thursday  
 Daylight Savings Time:

**Occupied Schedule**

	Start	End	Start	End
Sunday	00:00	00:00	00:00	00:00
Monday	05:00	19:00	00:00	00:00
Tuesday	05:00	19:00	00:00	00:00
Wednesday	05:00	19:00	00:00	00:00
Thursday	05:00	19:00	00:00	00:00
Friday	05:00	19:00	00:00	00:00
Saturday	00:00	00:00	00:00	00:00
Holidays	00:00	00:00	00:00	00:00

**Holidays**

	Start	End
1.	05/26	05/27
2.	07/04	07/04
3.	09/01	09/02
4.	11/28	12/01
5.	12/24	12/25
6.	00/00	00/00
7.	01/01	01/01
8.	00/00	00/00
9.	00/00	00/00
10.	00/00	00/00
11.	00/00	00/00
12.	00/00	00/00
13.	00/00	00/00
14.	00/00	00/00
15.	00/00	00/00
16.	00/00	00/00

Net BTC Zone Help

Lock

Monitor / Schedule / Auxiliary Schedule / Configuration / AHU Control / Test Variables / QA

13

System Control Unit - 200 (Front Offices)

File Network Options Help

CTS OOD OSF PNC R/O T/O System 200

Modulation		Staged Cool/Heat		Relay Output	
Cooling Fully On Above	55.0 °F	Throttle Range: A01	Cooling	Full On	10 Volts
Cooling Fully Off Below	52.0 °F	Minimum *		Full Off	2 Volts
Heating Fully Off Above	115.0 °F	Throttle Range: A02	Economizer	Full On	10 Volts
Heating Fully On Below	100.0 °F	Minimum *		Full Off	2 Volts
Econ. Fully Open Above	58.0 °F	Full On		Full Off	2 Volts
Econ. Minimum Below	55.0 °F	Minimum *		Full Off	2 Volts
Econ. Changeover Temp.	55.0 °F				
Econ. Changeover Source	Temperature Sensor				
Override OA Damper Position	Minimum				

\* Only Applicable when Throttle Range is in Economizer Modes

Net BTC Zone Help

Lock

Monitor / Schedule / Auxiliary Schedule / Configuration / AHU Control / Test Variables / QA /

49

Bypass Terminal Controller - 265 (Front Offices)

File Network Options Help

CTS OOD OSF PNC R/O T/O System 200

Pressure Sensor

Static Pressure 0.92 in wg

Logging Control

Logging Interval 5 min

Log Alarm

Control Settings

Identifier Front Offices

Unit Address 265

Bypass Pressure Setpoint 0.95 in wg

Bypass Pressure Deadband 0.10 in wg

Damper Modulation Band 0.20 in wg

VFD Pressure Setpoint 0.90 in wg

VFD Pressure Deadband 0.10 in wg

VFD Full Scale Response Time 30 sec

Pressure Offset Adjust 0.00 in wg

Pressure Slope Adjust 0.00 in wg

Net SCU Zone Help

Lock

Monitor and Configuration / Test Variables /

30



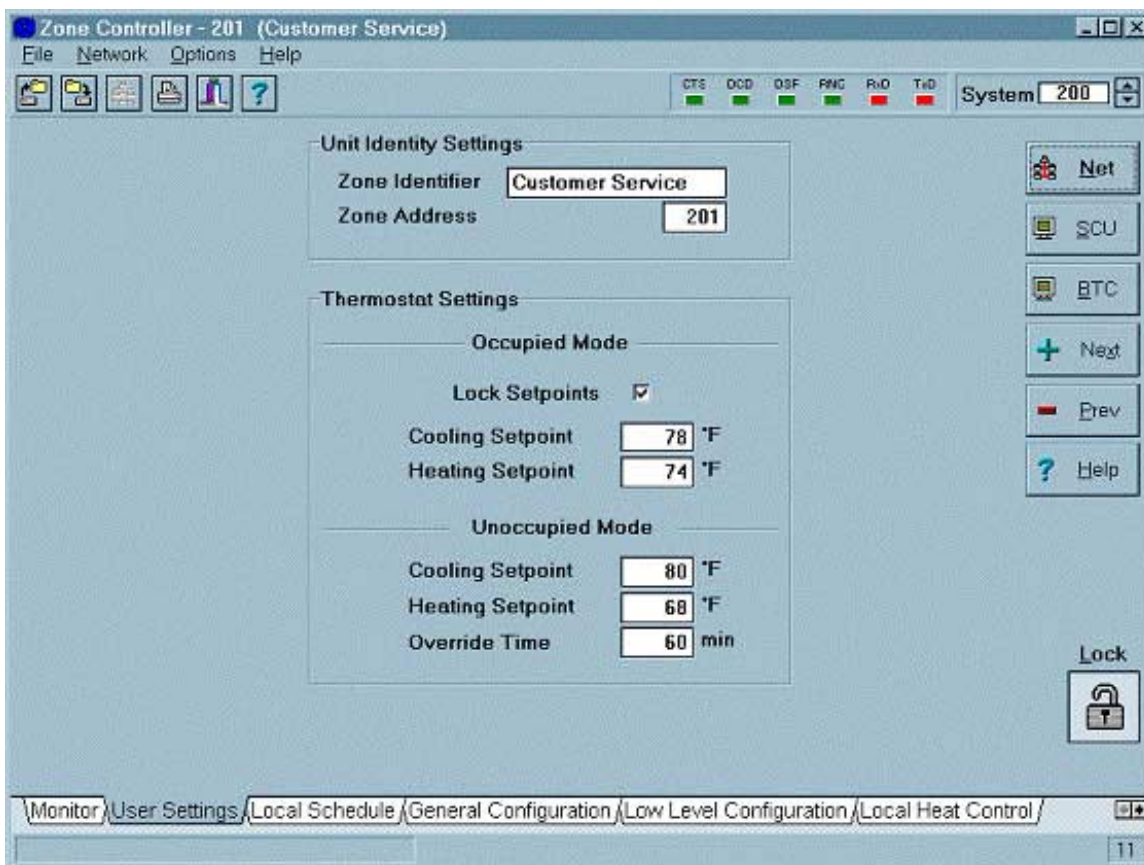
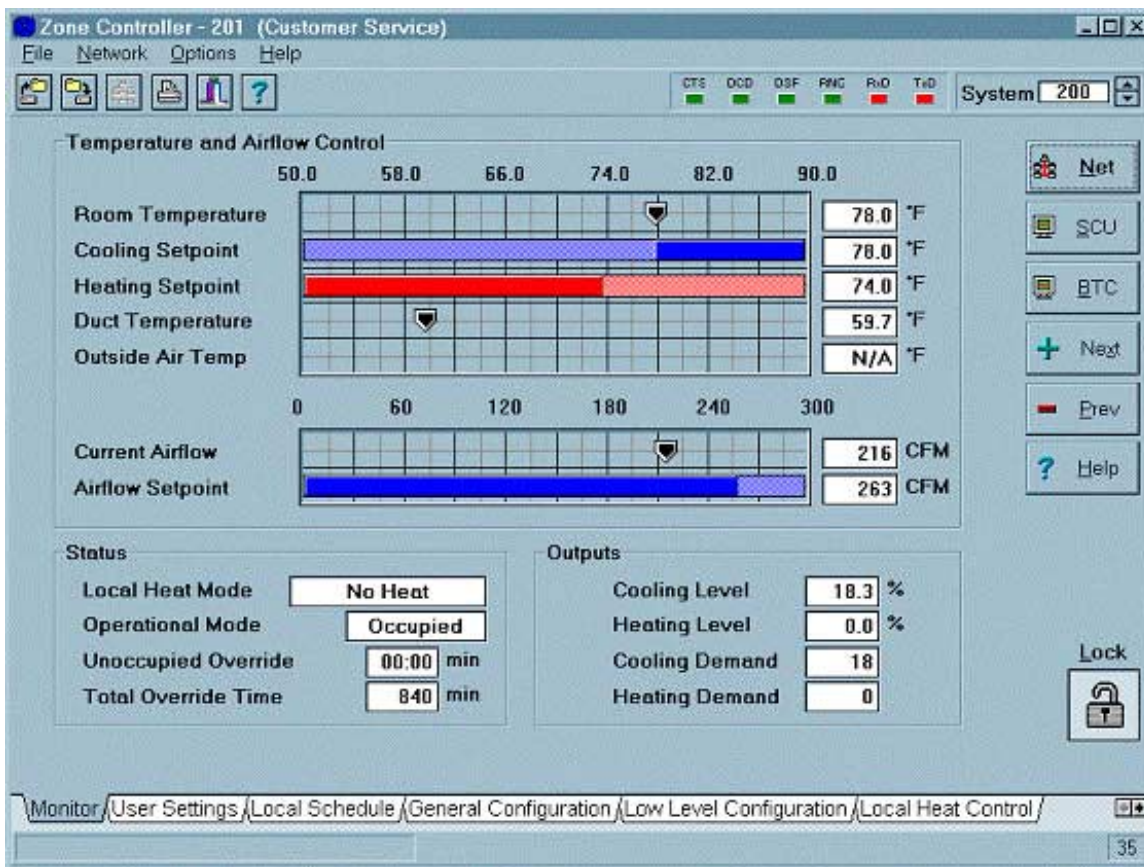

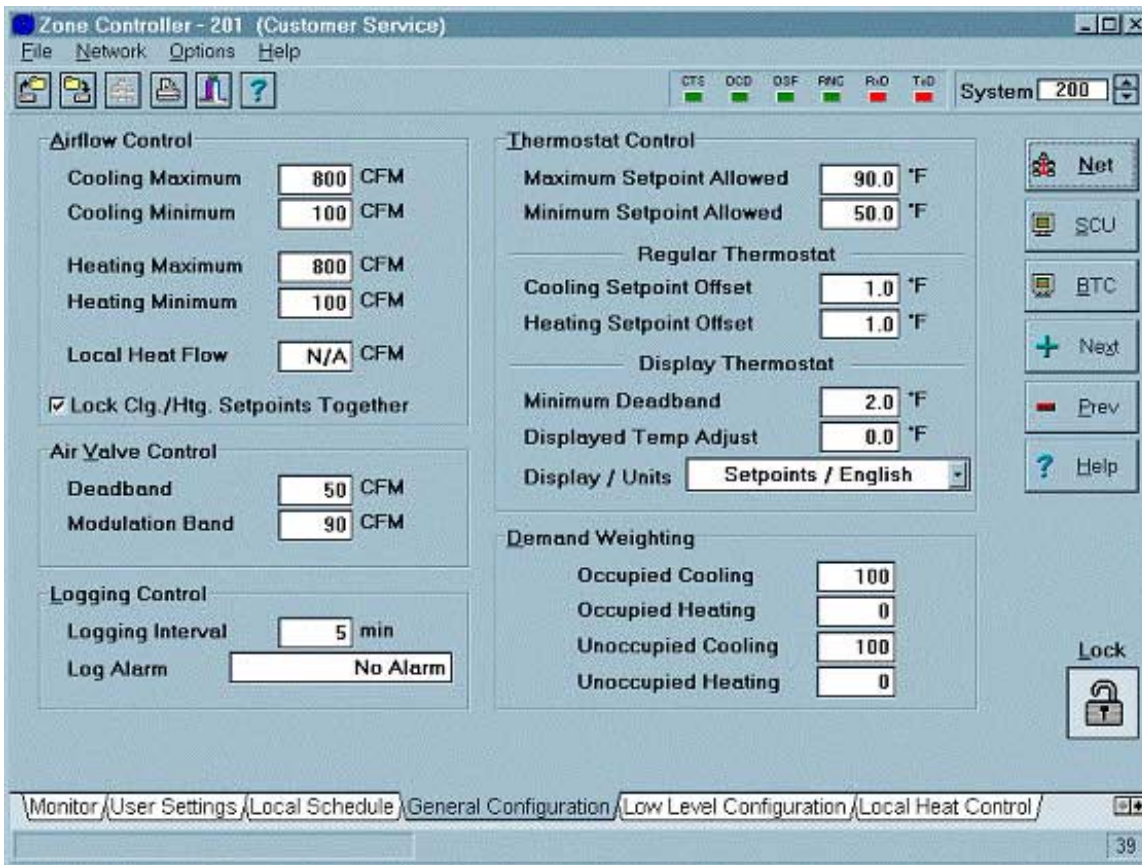

**Zone Controller - 201 (Customer Service)**

File Network Options Help

CTS DCD OSF PNC R/O T/D System 200

**Airflow Control**

Cooling Maximum 800 CFM  
Cooling Minimum 100 CFM  
Heating Maximum 800 CFM  
Heating Minimum 100 CFM  
Local Heat Flow N/A CFM

Lock Clg./Htg. Setpoints Together

**Air Valve Control**

Deadband 50 CFM  
Modulation Band 90 CFM

**Logging Control**

Logging Interval 5 min  
Log Alarm No Alarm

**Thermostat Control**

Maximum Setpoint Allowed 90.0 °F  
Minimum Setpoint Allowed 50.0 °F

**Regular Thermostat**

Cooling Setpoint Offset 1.0 °F  
Heating Setpoint Offset 1.0 °F

**Display Thermostat**

Minimum Deadband 2.0 °F  
Displayed Temp Adjust 0.0 °F  
Display / Units Setpoints / English

**Demand Weighting**

Occupied Cooling 100  
Occupied Heating 0  
Unoccupied Cooling 100  
Unoccupied Heating 0

Net  
SCU  
BTC  
Next  
Prev  
Help

Lock

Monitor / User Settings / Local Schedule / General Configuration / Low Level Configuration / Local Heat Control /

39

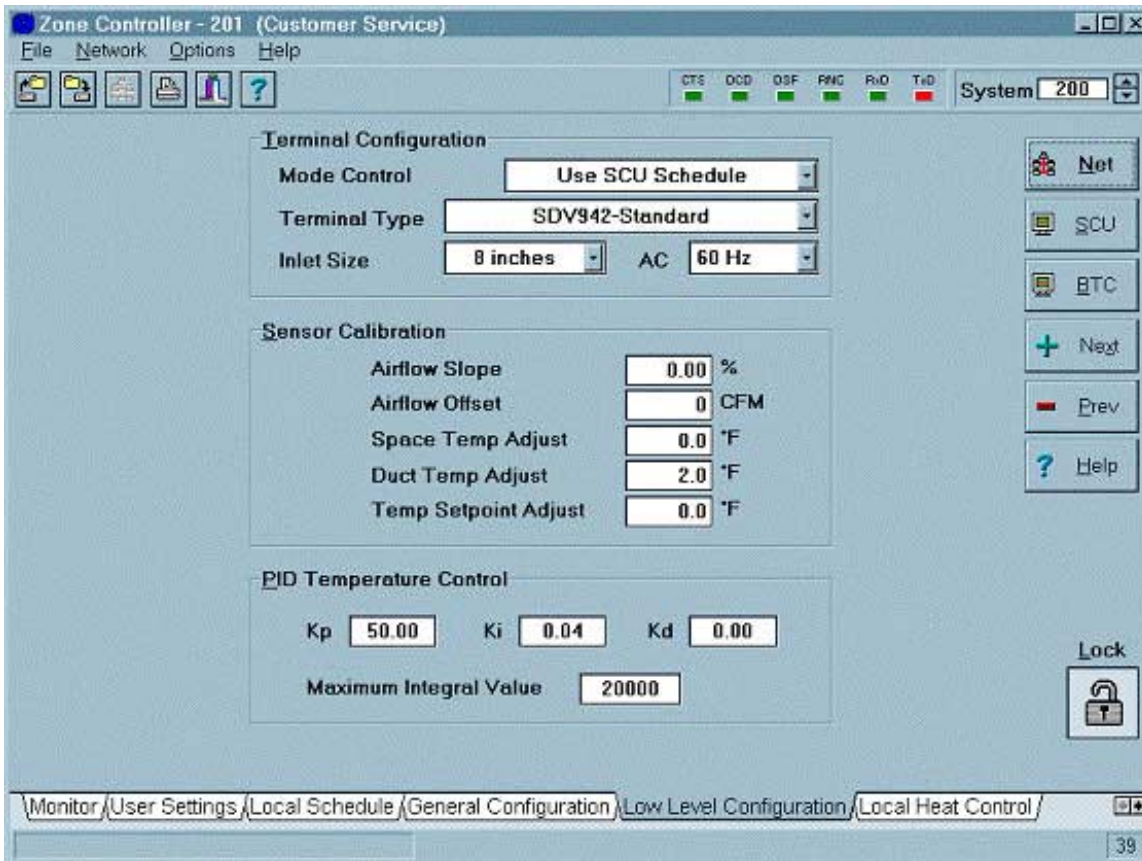

**Zone Controller - 201 (Customer Service)**

File Network Options Help

CTS DCD OSF PNC R/O T/D System 200

**Terminal Configuration**

Mode Control Use SCU Schedule  
Terminal Type SDV942-Standard  
Inlet Size 8 inches AC 60 Hz

**Sensor Calibration**

Airflow Slope 0.00 %  
Airflow Offset 0 CFM  
Space Temp Adjust 0.0 °F  
Duct Temp Adjust 2.0 °F  
Temp Setpoint Adjust 0.0 °F

**PID Temperature Control**

Kp 50.00 Ki 0.04 Kd 0.00  
Maximum Integral Value 20000

Net  
SCU  
BTC  
Next  
Prev  
Help

Lock

Monitor / User Settings / Local Schedule / General Configuration / Low Level Configuration / Local Heat Control /

39



Designing an ETVT-II system is a fairly straightforward process. The paragraphs which follow provide general suggestions on ETVT-II system application and also outline the actual component selection and layout procedure.

### **Handling Load Diversity**

The ETVT-II system was designed to meet the specific needs of small buildings requiring a simple, cost effective means to provide multiple zone comfort control. It was not intended to be used on all applications; therefore, care must be taken when applying this system.

On buildings demanding simultaneous heating and cooling, the ETVT-II system should not be used with one single unitary heating / cooling unit unless some type of local zone heating fan terminal or reheat is used. The system is intended for buildings or areas with zones that have similar load profiles (i.e. at any time during occupied periods, all of the zones are calling for either heating or cooling). Buildings that have large internal core areas in conjunction with substantial exterior glazing must be examined carefully.

The ability of the ETVT-II system to incorporate fan powered and reheat terminal units greatly expands the capability of the system to handle diverse loads. This is particularly true of buildings with a small number of zones which require perimeter heating during certain periods of the day while the rest of the zones require cooling. The option for adding reheat at the zone terminal is best suited for accommodating a small number of problem zones. Buildings which require continuous heating on the perimeter zones and continuous cooling on the interior zones during cold days would require reheat on all perimeter zones. An alternative solution to this is to use multiple ETVT-II systems and multiple heating / cooling units or to use a mix of cooling only VAV units and fan powered terminals with reheat.

### **Bypass Configurations**

When using a constant volume air handler with a variable volume control system, there must be a means for diverting air back from the supply duct to the return duct as the zone terminals modulate closed. This is done by means of BPV-01 and BPV-02 bypass terminals. As the system static pressure increases, the bypass opens to unload the fan, thereby maintaining constant static pressure.

The bypass system can be configured to either dump air from the supply to the return via a section of ductwork or by dumping supply air into the plenum when the application permits. Typically, one configuration is chosen over the other based primarily on physical constraints.

One concern when dumping air back to the plenum for an open air return is to make sure that the air handling equipment includes the necessary options to avoid pressurization of the plenum. This can become a problem if the roof top includes an economizer. When the unit starts to pull outside air for economizer cooling, more air is entering into the building than is being exhausted and causes the return air plenum to pressurize. Without some means for exhausting this excess air, cold plenum air will seep back into the zone through return air openings and cause possible temperature control problems.

### **System Control Unit Selection**

A System Control Unit is required for control of each air handling unit.

### **System Control Unit Placement**

Since the SCU contains the operator's panel and service tool port, the SCU should be placed in a location where it is relatively easy to access. At the same time, it is important to prevent unauthorized access to the override control switches. The SCU is typically placed in a mechanical room or closet.

**SCU Discharge Sensor Placement**

The SCU's discharge temperature sensor is installed in the discharge ductwork of the HVAC unit. This sensor permits the SCU to control the activation or deactivation of heating and cooling stages thereby controlling the discharge air temperature. The sensor should be placed where it will accurately sense the discharge air temperature from the HVAC unit, preferably between the HVAC unit discharge and the first bypass terminal.

**Zone Terminal Unit Sizing**

Proper sizing of the zone terminal units is critical in any HVAC system installation. The acoustical performance and overall comfort level in the zone depends on this selection. Once the CFM requirements for each zone have been determined through load analysis calculations, refer to the SDR General Selection Table on page 13 or the SGX General Selection Table on page 15. In these tables you will find noise criteria and pressure drop data for all terminal sizes at different air volumes (CFM). Units should be selected for the maximum CFM setpoint at the mid-range to upper mid-range of the table to ensure maximum operating efficiency. At the low end of the table, the ability to closely control is reduced; and, at the high end of the table, excessive noise and pressure drop may be experienced. Select units at the midrange of the General Selection Table for most applications.

**Fan Terminal Unit Selection**

Fan terminal units should be selected from the Series or Parallel Fan Terminal catalogs. With central changeover systems where supply air temperature exceeds 120°F in the heating mode, parallel fan terminals should be used in lieu of series fan terminals.

**Inlet and Discharge Options**

All zone terminal units include standard round inlets and rectangular slip and drive discharge.

**Zone Controller Airflow Ranges**

UNIT SIZE	PRESSURE INDEPENDENT	
	ETVT-II Series Digital Electronics	
	Min. <sup>1</sup>	Max. <sup>2</sup>
4	35	225
5	55	350
6	65	550
8	120	1000
10	195	1600
12	280	2300
14	400	3100
16	550	4100
19	1025	6500
22	1450	8000

**NOTES:**

1. Factory CFM settings (except zero) will not be made below this range due to reduction in control accuracy.
2. Above ranges are maximum ratings. For ideal selections, do not size unit at maximum listed volumes.

**Communications Connection Option**

All zone terminal controller thermostats include a port which allows a Windows® compatible computer to be connected directly to the zone thermostat through an ETINT1 portable service tool interface.

**Zone Terminal Unit Placement**

Placement of the zone terminal units will be dictated primarily by building layout constraints. It is important, however, to have a straight duct run into each zone terminal unit that is at least as long as 1.5 equivalent duct diameters. This should be done to prevent excessively turbulent airflow conditions at the airflow sensor which can cause inaccurate airflow readings.

**Zone Terminal Placement**

As with any thermostat, the ETVT-II zone thermostats should be located where they will best reflect the temperature of air which is being experienced by the

zone's occupants. Typical guidelines for thermostat placement should be followed, such as avoiding placing the thermostat where a diffuser will be blowing air directly on it or where it will receive direct solar exposure. In addition, internal heat sources such as copiers, computers, coffee makers, and refrigerators should be avoided.

### **Bypass Terminal Unit Sizing**

When sizing a bypass terminal, the unit should be selected to handle approximately 80% of the nominal CFM for the air handler, minus the total of the minimum CFMs for all of the zones (including any constant volume zones). For most applications this would typically be about 325 CFM per ton minus 10-20% of the total zone CFM requirements. See page 24 for an example of bypass terminal sizing.

Once the CFM requirements have been determined for the bypass terminal, refer to the SDR General Selection table on page 13. The bypass terminal should be selected at the upper mid-range of the performance tables to ensure that adequate pressure drop is maintained across the terminal unit during 100% bypass. It is very important that the bypass terminal is not oversized since this greatly affects the range of control. Also, never select units at the highest end of the General Selection table. If the total bypass CFM requirement is less than 6000 CFM, select an appropriate BPV-01 bypass terminal unit. If the total CFM requirement exceeds 6000 CFM, use a BPV-01 bypass terminal unit and one or more BPV-02 terminal units, all of equal size.

### **Bypass System Selection**

Select a BTC-01 bypass terminal controller and the appropriate bypass terminal unit(s) (see page 11). For systems utilizing a variable volume roof top unit, a bypass system is not required.

### **Bypass Terminal Unit Placement**

The bypass terminal unit should always be installed directly off the supply main, before any branch take-offs, and should be located in the immediate vicinity of the return air opening of the HVAC unit.

### **Bypass Terminal Controller Placement**

The BTC-01 bypass terminal controller contains the static pressure transducer and is connected by a short piece of plenum-rated tubing to the static pressure probe. The static pressure probe is typically located down approximately 2/3 of the longest duct run away from takeoffs. Connections are made from the bypass terminal controller to the bypass terminal unit(s) and also back to the SCU.

### **Communications Cable Routing**

For proper communications it is very important that the communications cable is started at the System Control Unit and then connected from controller to controller in a single daisy chain fashion. Loops, tees, or splits in the cable may cause intermittent or total communications failure. Refer to the ETVT-II Installation and Startup Manual for detailed information.

## **SAMPLE APPLICATION**

The building diagrammed on page 25 is typical of many real-world applications of the ETVT-II system. Although it is a relatively small building it has a wide range of heating and cooling requirements.

In this example, the rooftop unit is a 15 ton 2-stage unit with a nominal 6000 CFM capacity. For this example each zone's minimum CFM will be assumed to be equal to 20% of the zone's maximum CFM.

### **Load Diversity Check**

With the exception of Zones 3 and 5, this building would be assumed to have a very uniform load profile. Since Zone 3 is an entrance foyer to the building, the doors in that zone would probably be opened frequently which would cause the load to fluctuate. There is also considerable glazing on the north wall of the entrance foyer area which adds to the problem. For Zone 3 it is recommended that some means of reheat be used to maintain space comfort. Using the SDV945 zone controller and baseboard reheat or terminal unit reheat will help compensate for zones such as this in order to maintain overall building comfort.

The other possible problem zone is Zone 5. This is an executive office having glazing on the North and East exposures. In the early evening, this zone could require heating on certain days while the rest of the building required cooling. Again, an SDV945 zone controller is recommended for this zone in conjunction with some type of electric reheat.

Since the load profiles for the rest of the zones would remain fairly uniform throughout the day, they can be controlled using standard SDV942 zone controllers.

### **System Control Unit Selection**

Since the rooftop unit is a 2-stage heating / cooling unit, an SCU-LT8 would be selected for the System Control Unit. The SCU-LT8 includes a total of 8 relays for control of the fan, 2 heating stages, and 2 cooling stages with 3 relays remaining open for future use.

### **Zone Terminal Selection**

Zone terminal unit selections are made using the SDR Specifications Table on page 13 or the SGX Specifications on page 15. Based on the zone CFMs indicated on the building diagram, the table below shows typical zone terminal unit selections.

<b>ZONE</b>	<b>CFM</b>	<b>SIZE</b>
1	500	8"
2	500	8"
3	1000	10"
4	500	8"
5	600	8"
6	375	6"
7	500	8"
8	500	8"
9	350	6"
10	350	6"

### **Bypass Terminal Selection**

As is typical in most installations of this type, the rooftop unit in this example is assumed to be a constant volume unit. Therefore, it requires one or more bypass terminal units and a bypass terminal controller. The total bypass CFM is calculated as shown below.

$$\begin{aligned}
 &\text{Total Bypass CFM} \\
 &= (\text{Rooftop Unit CFM}) \times 80\% \\
 &\quad - (\text{Variable Volume Zone CFM} \times 20\%) \\
 &\quad - (\text{Constant Volume Zone CFM})
 \end{aligned}$$

$$\begin{aligned}
 &\text{Therefore:} \\
 &= (6000 \text{ CFM}) \times 0.80 \\
 &\quad - (5175 \text{ CFM} \times 0.20) \\
 &\quad - (500 \text{ CFM}) \\
 &= 3265 \text{ CFM}
 \end{aligned}$$



The total variable volume zone CFM is the sum of the maximum CFMs for zones 1 through 10. The total constant volume zone CFM is the sum of the CFMs for the constant volume zones (the two bathrooms and the file storage room).

The maximum volume that can be handled by a single bypass terminal unit is 6000 CFM. Therefore, in this example one bypass terminal unit is required that is capable of bypassing 3265 CFM. Referring to the SDR General Selection table on page 13, the ideal selection would be to use one Size 16 terminal. A BPV-01 would be used for the bypass terminal.

**System Components Summary**

In addition to the rooftop unit, the 13 components listed below provide a complete ETVT-II system for the building in this example:

**System Control Components:**

1 SCU-LT8

**Zone Control Components:**

3 SDV942 - Size 6

5 SDV942 - Size 8

1 SDV945 - Size 8

1 SDV945 - Size 10

**Bypass Control Components:**

1 BTC-01

1 BPV-01 - Size 16.

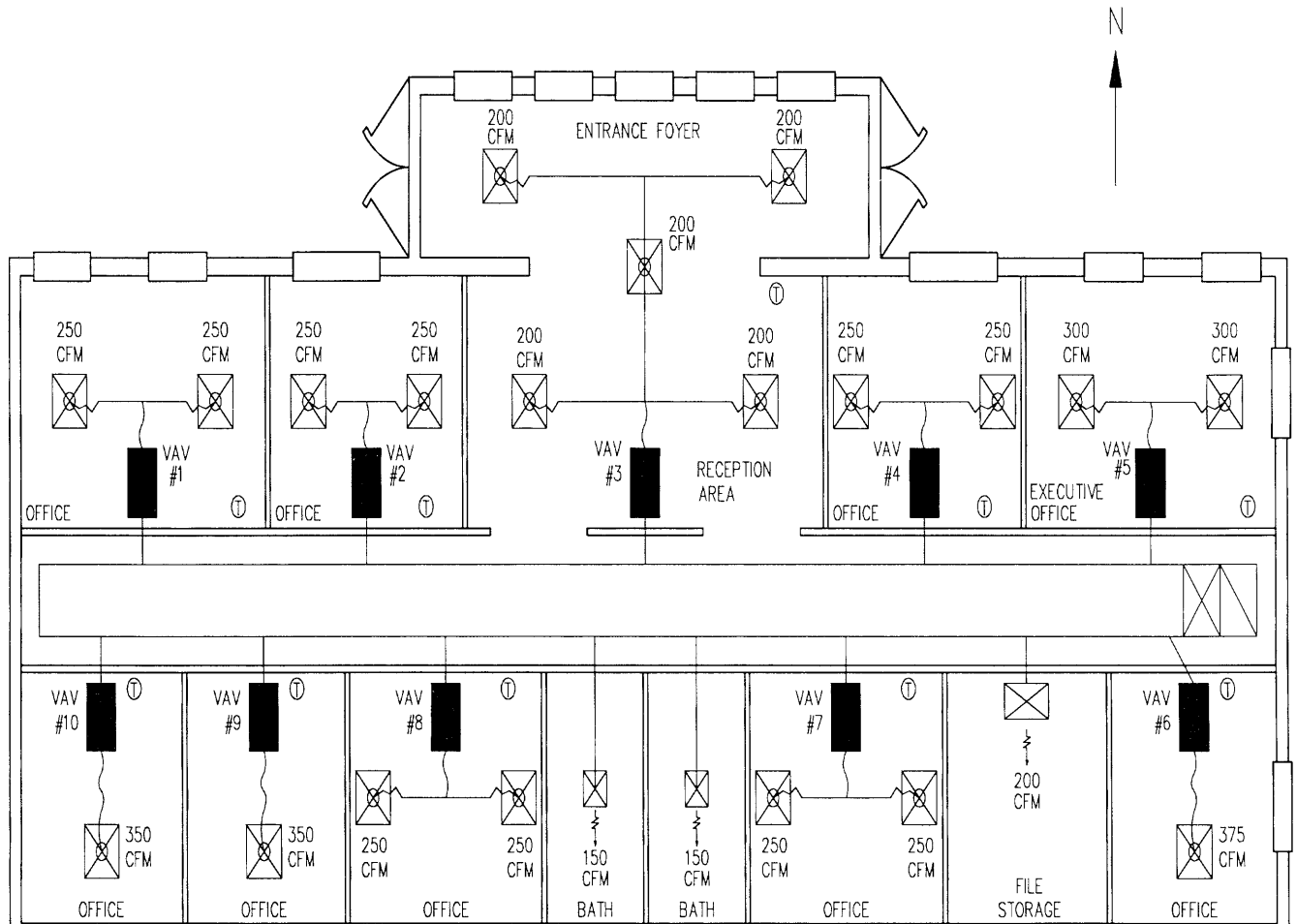

## GUIDE SPECIFICATION

A system of VAV terminal box controllers and a System Control Unit shall be supplied under this contract. All zone controllers shall be furnished and mounted by the selected VAV box manufacturer as an integral portion of the air terminal, along with the System Control Unit (SCU), which is field installed. The control system shall be the Environmental Technologies ETVT-II system as specified below. The zone controllers shall be direct digital, pressure independent, with outputs for control of the unit damper actuator, optional heat, and optional induction fan.

### HARDWARE

For control of the HVAC unit, provide a System Control Unit (SCU), consisting of a microprocessor based controller, an AHU discharge temperature sensor, all enclosures, and application software. The system controller shall be ETL listed as an assembly.

For each VAV box, provide a VAV zone controller consisting of a microprocessor based controller, actuator, flow compensated differential pressure transducer, enclosure, and application software.

Provide, if required, at least one pressure relief terminal (bypass terminal) with an electronic static pressure controller, electric actuator, and pressure transducer.

All electric actuators must incorporate a current limited DC motor. Actuators incorporating AC synchronous motors are not acceptable.

**Casing** shall be constructed of 22 gauge zinc-coated steel, mechanically assembled and sealed to form an air-tight construction with maximum casing air leakage of two (2) percent at 3" W.G. Spot-welded casings are not acceptable.

**Insulation** shall line the interior casing walls and shall not be less than 1/2" thick dual density fiberglass with 4 p.c.f. skin outer layer. The material must comply with UL181 and NFPA 90-A with no raw edges exposed to the airstream. All insulation shall be adhered to the unit casing by two means: i.e. an NFPA 90-A approved adhesive and a mechanical fastener welded to the unit casing wall. Units utilizing approved adhesive only are not acceptable. Raw insulation edges on the discharge of the unit must be covered with metal liner to eliminate flaking of insulation during field duct connections.

**Valve Assembly** shall be manufactured of a 22 gauge air valve body to handle high pressure and a 16 gauge com-

posite damper blade with key attached to a solid shaft. The shaft shall have a position indicator marked on the end for verification of damper position. Two galvanized damper blades shall sandwich closed cell foam gasket material, providing for minimum valve leakage. Damper leakage shall not exceed two (2) percent of unit's maximum rated capacity with inlet pressure up to 6" W.G. Damper shall pivot in Delrin® self lubricating bearings that are unaffected by temperature and humidity. The valve assembly shall have built-in maximum and minimum heavy gauge mechanical stops to prevent over-stroking of the damper.

**Airflow Sensor** must be equipped with a center averaging chamber and have multi-axis sampling tubes. The sensor shall be designed to provide a differential pressure signal which is amplified at least 2.5 times the normal velocity pressure, over the full capacity range of the terminal. Pressure measuring taps shall be provided external to the unit with an airflow curve for ease of air balancing.

All the above components shall be original equipment manufactured and furnished by the VAV unit manufacturer. A 24 VAC (output) transformer shall be mounted at the SCU, bypass damper, and each zone controller to match the power requirements of the building.

### CONTROL

The System Control Unit (SCU) shall poll all zone controllers at least once every sixty seconds to determine the optimum mode of operation for the HVAC unit. This optimization shall be configurable through supplies software or operator panel to ensure optimum system operation in the building. It shall determine the current HVAC unit's heating or cooling status, by a zone weighting factor unique to each unit, to allow optimum system control. For operation in the event of communications failure, the SCU shall be equipped with manual indicating override switches to permit continued fan, cooling, or heating operation. Also, the SCU shall be equipped with one mechanical fan/cooling override switch and one mechanical fan/heating override switch for temporary system operation in the event of SCU failure.

The SCU shall contain a battery-backed internal time clock for determining system scheduling of occupied periods. The time clock shall be quartz crystal locked and shall have an accuracy better than +/- 0.0023% @ 77°F. An optional external time clock or contact closure shall be able to override the system schedule.

Each VAV unit shall be capable of complete stand-alone pressure independent operation and shall not depend on information from any other element in the building (including the SCU or other VAV terminals) for effective room temperature control. Failure of any component in the unit shall not cause the interruption of control by any other VAV controller. The zone controllers shall have multiple control modes, each with unique temperature and flow setpoints, for optimum autonomous operation. Each VAV unit shall control zone temperature using a proportional, integral, and derivative (PID) control algorithm.

#### **SETPOINT STORAGE**

All control setpoints shall be maintained in non-volatile memory (EEPROM) to enable unit reset after a power failure. All setpoint variables shall be established through the system control unit operator's panel or through the communications network using a standard Windows® compatible personal computer or laptop computer. Cable and software shall be supplied by the manufacturer.

#### **ROOM TEMPERATURE SENSORS**

The zone controller's room temperature sensors with an integral temperature setpoint adjustment shall be provided by the VAV terminal manufacturer. Room temperature sensor enclosures shall be of high-impact plastic and be equipped with a communication connection at the zone controller. The temperature sensor enclosure shall have an optional tamper-resistant cover. The desired room temperature set at the room sensor shall be limited in range by programmed limits at the controller. Sensors shall have an accuracy of  $\pm 0.4^{\circ}\text{F}$  @  $70^{\circ}\text{F}$ . All units shall have a night set-back override switch to enable a temporary system reset to daytime operation.

#### **FLOW MEASUREMENT**

All zone controllers shall be equipped with a multi-axis center averaging flow sensor in the unit inlet, which shall be connected to a flow compensated pressure transducer mounted on the controller. The flow measurement shall be independent of space (plenum) temperature within the range of  $30^{\circ}\text{F}$  to  $150^{\circ}\text{F}$  or supply air temperature from  $50^{\circ}\text{F}$  to  $110^{\circ}\text{F}$  to within  $\pm 5\%$  of rated flow. Minimum resolution of the flow signal shall be to within 15 FPM from 400 FPM to 3000 FPM. The measured flow shall be maintained within set maximum and minimum limits regardless of inlet pressure.

#### **DUCT TEMPERATURE SENSOR**

The System Control Unit shall have a duct temperature sen-

sor for use in monitor and control of the HVAC unit's discharge air temperature. Each zone controller shall have a supply inlet duct temperature sensor for determining change-over operation. Duct temperature sensors shall be interchangeable  $\pm 1^{\circ}\text{F}$  at  $70^{\circ}\text{F}$ .

#### **REHEAT OPTIONS**

Zone controllers shall optionally have the capability of controlling either a tri-state hot water valve or up to two steps of electric heat. The heater and controller shall be listed by ETL or UL as an approved assembly and shall be provided by the terminal unit manufacturer. The zone controllers shall optionally be capable of controlling an induction fan for constant volume (series flow) or sequenced induction (parallel flow) operation, if desired. All units including the controller shall be listed by ETL as an assembly.

#### **CONNECTIONS**

Connections between controllers and wall mounted sensors shall be made by factory provided Quick-Wire™ cables. Communications between units shall be made with 20-22 AWG twisted/shielded pair with drain, plenum approved cable.