

This sequence provides dual duct constant volume discharge control. When the space temperature is warm, the cold damper maintains maximum cooling airflow setpoint while the hot damper maintains minimum heating airflow setpoint. As the space temperature drops, the cold damper modulates closed while the hot damper opens. As the space temperature continues to fall, the cold damper maintains minimum cooling airflow setpoint and the hot damper maintains maximum heating airflow setpoint. Airflow limits for each deck are located on that deck's controller.

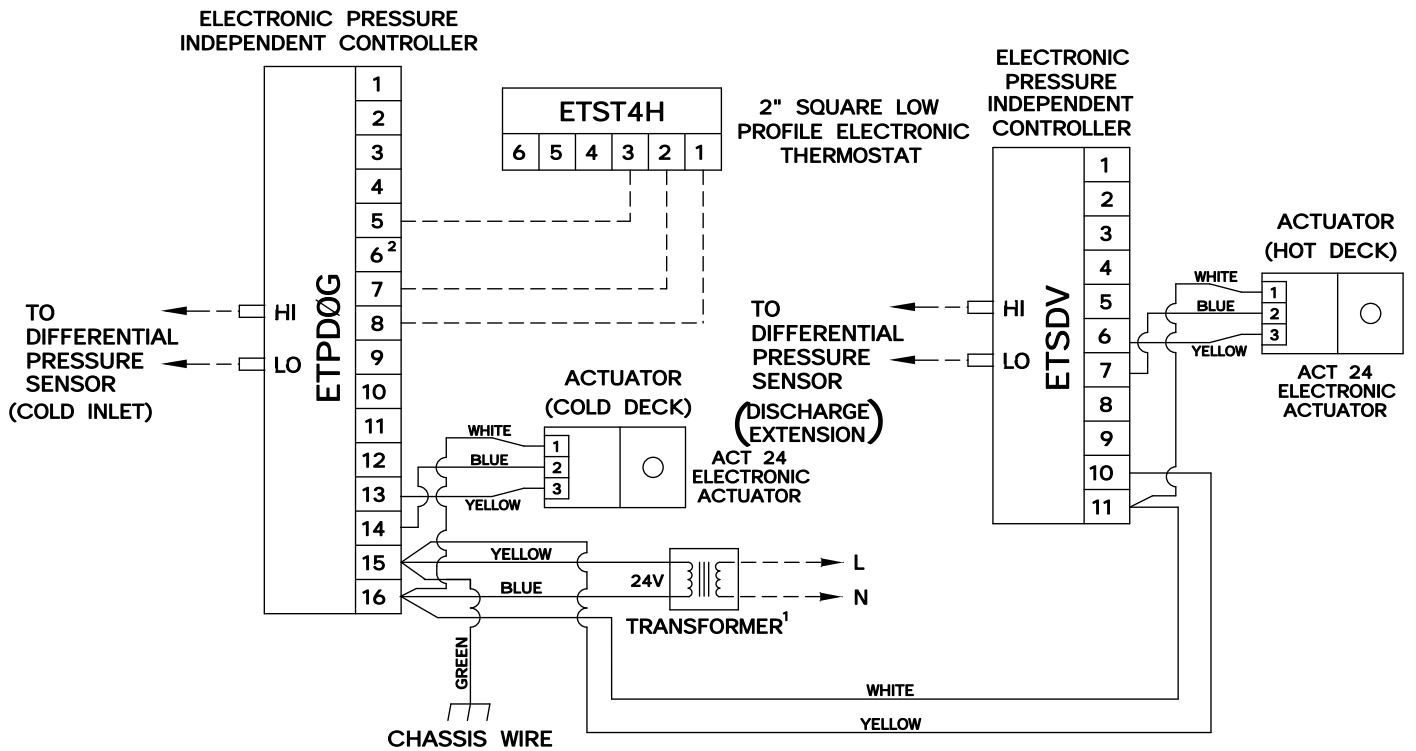
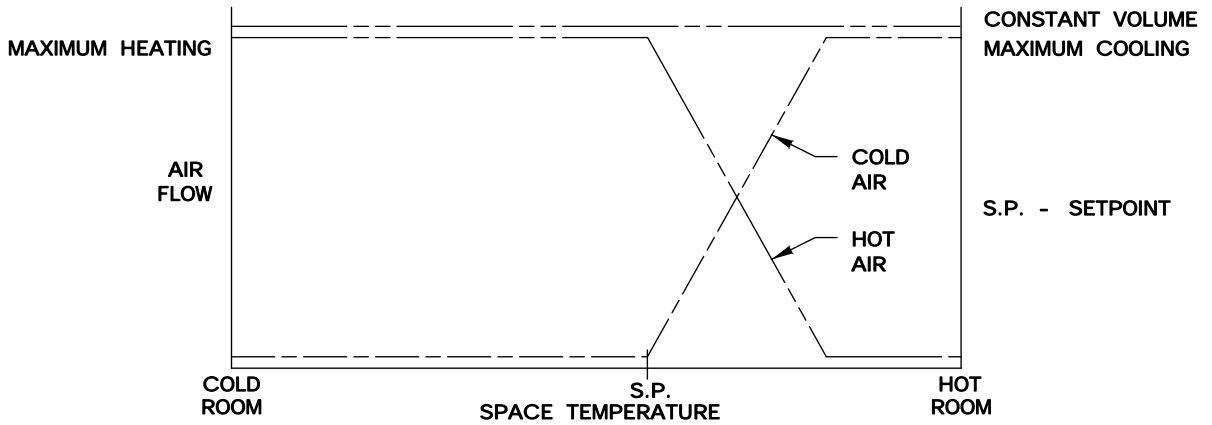

<sup>1</sup> MINIMUM 40 VA  
<sup>2</sup> MAY BE USED AS BALANCE POST TO SET MINIMUM AND MAXIMUM CFM

----- FACTORY TUBING  
 - - - - - FIELD WIRING  
 \_\_\_\_\_ FACTORY WIRING

<b>ENVIRO-TEC®</b> ENGINEERING FOR EXCELLENCE	DT701SB
	PRESSURE INDEPENDENT ELECTRONIC CONTROLS
DRAWN BY: WDD    DATE: 09/18/00    REV NO: 00    REV DATE:    APPROVED BY: W.E.	DRAWING NO: <span style="font-size: 1.2em; font-weight: bold;">21073</span>