

A reverse acting, one-pipe thermostat is required. Damper is normally open. Optional reheat control will require a normally closed hot water valve or a normally open P.E. switch. On a rise in space temperature, airflow is increased. On a drop in space temperature, airflow is decreased. Maximum and minimum CFM setpoints are field adjustable. Control of supply air to room is between these setpoints. If the space temperature continues to drop at minimum airflow, the thermostat will energize an electric heater or hot water coil valve to provide reheat.

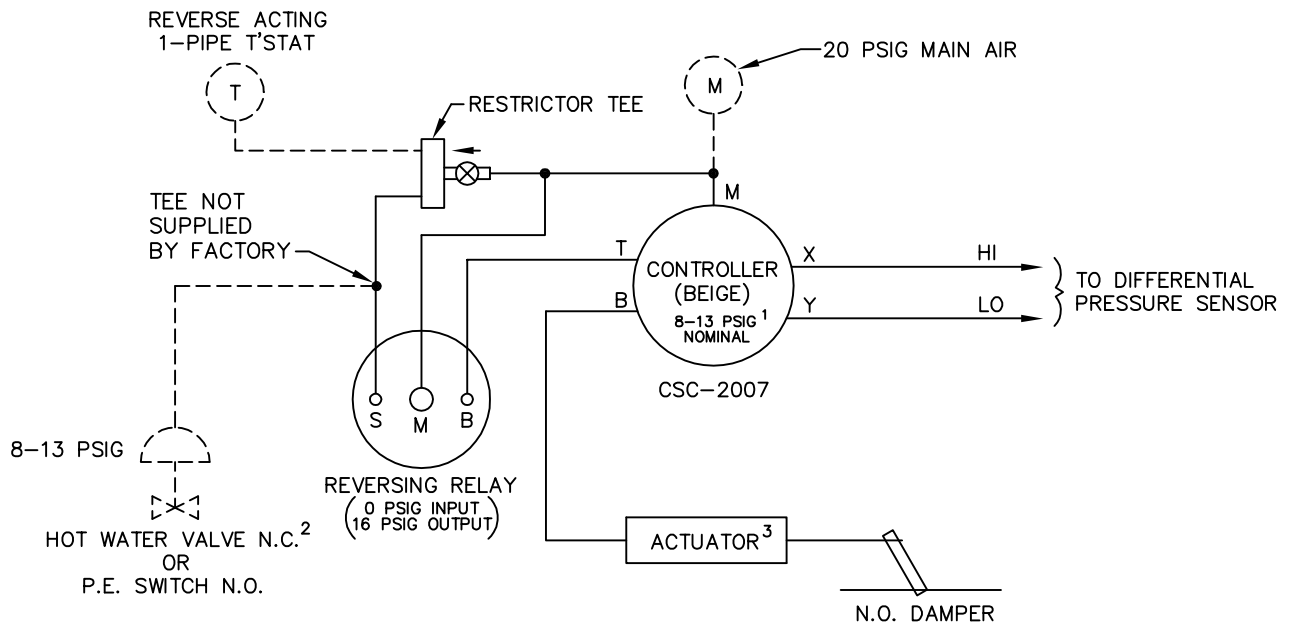
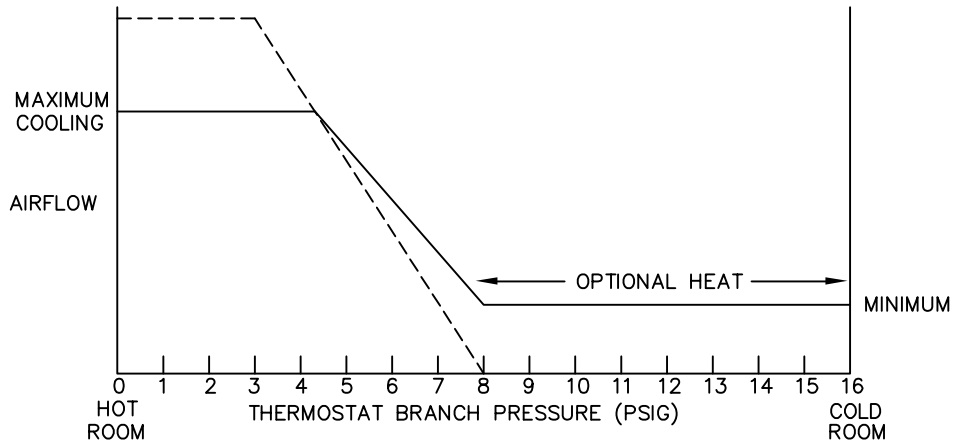

- 1 CONTROLLER REQUIRES FIELD CALIBRATION AND SET UP UNLESS OTHERWISE SPECIFIED. CONTROLLER RESET RANGE WILL VARY WITH AIR FLOW LIMITS.
- 2 HOT WATER VALVE SUPPLIED BY OTHERS P.E. SWITCH IS INCLUDED IN ELECTRIC HEATER
- 3 UNIT SIZES 19 & 22 UTILIZE DUAL ROTARY PNEUMATIC DAMPER ACTUATORS

— FACTORY PIPING - - - - FIELD PIPING

PNEUMATIC AIR CONSUMPTION 1.1 SCFH



TITLE:		SD406R	
PRESSURE INDEPENDENT PNEUMATIC CONTROLS			
THIS DRAWING CONTAINS PROPRIETARY DATA. UNAUTHORIZED DISCLOSURE, REPRODUCTION, OR USE IS STRICTLY PROHIBITED WITHOUT WRITTEN PERMISSION			

DRN BY: AWW	DATE: 05/09/94
CKD BY: WAE	DATE: 08/19/08
REV: 04	

DRAWING NO.
16352

UNCONTROLLED WHEN PRINTED